

Injectors

General

Injectors have the task, during all driving conditions, to inject the correct amount of fuel calculated by the ECU. For good fuel atomisation and small condensation loss an engine specific distance to the inlet valve and injection angle are built in to the injector.

Function

Injectors operate electro magnetically. The electrical impulses for opening and closing the injector sent from the ECU, are calculated by analysing sensor data and driving conditions. Injectors are made of a valve body with a solenoid winding, a needle jet guide and a needle jet with a solenoid armature. When the ECU sends a voltage to the solenoid winding, the needle jet lifts of the seat and opens a jet. If the voltage is removed a spring reseats the needle jet and close the jet. The exact flow, by an open injector, is defined by the precision jet. To inject the correct fuel amount, for each driving condition, the ECU calculates, in conjunction with the fuel pressure, the opening time of the injector. Consequently it ensures that the correct amount of fuel is injected.

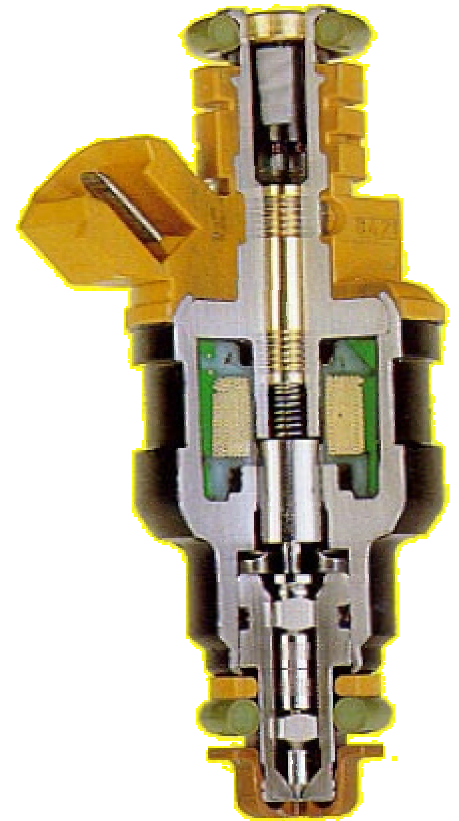

Effects of failure

A faulty injector can cause the following:

- Difficult starting
- Engine stalls in idle
- Impairment of the exhaust emission specifications
- Higher fuel consumption
- Lower engine performance

Causes of failure:

- Blocked filter element inside the injector

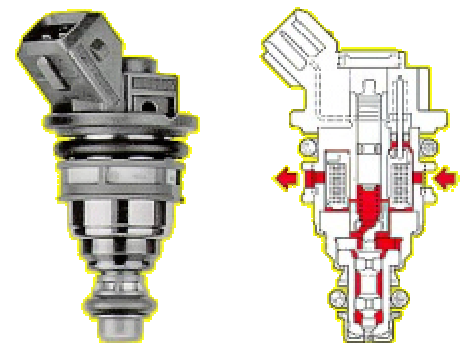



- Badly closing needle jet through soiling, combustion residue and additive deposit build up
- Soiled jet
- Coil short circuit
- Secondary damage: reduction of the engine life and catalytic converter

Diagnostics

The fault recognition can be carried out when the engine runs or stopped.

Fault recognition when the engine runs:

1. With a cylinder comparison check and an exhaust test at the same time you can see from the reducing engine speed and the exhaust specifications HC and CO, how much fuel is injected. The system is working well when all specifications are met. When the specifications are highly different it is possible that too much or not enough fuel is being injected (high HC and CO = a lot of unburned fuel/ low HC and CO = less unburned fuel). The cause can be a faulty injector.
2. With the oscilloscope you can observe the injection signal from the ECU. For this, connect the check wire onto the injector to the control wire from the ECU and the other one to vehicle ground. When the engine runs you can see on the signal picture the voltage and the pulse period (opening time). When the throttle valve is opening, during the acceleration the impulse period must increase and by a constant engine speed (3000 rpm) it should reduce to the same specification as at idle speed. The results of the individual cylinders can be compared and provide information about errors for example faulty voltage.
3. It is important to check the fuel pressure, to exclude the possibility other faulty components(fuel pump, fuel filter, pressure regulating valve). Also the inlet and outlet system must be checked for tightness.

Fault recognition when engine is stopped.

1. Check the wiring harness between the ECU and the



Soiled Injector tip/hole

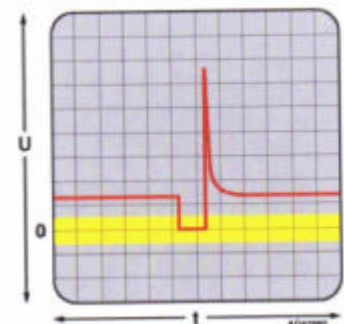

Injector signal on the Oscilloscope

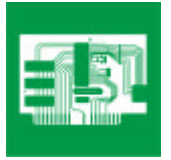

injectors for continuity (wiring diagram needed for pin definition). For this check, remove the ECU and injector plugs. Measurement with a Ohmmeter.

Measured value: ~ 0 Ohm

2. Check the wiring harness between the ECU and the injectors for short circuit to earth. Measurement between each wire and vehicle ground, ECU plug removed. Measured value: >30 Mohm
3. Check the injector coil for continuity. Measurement with a Ohmmeter between the two pins of the injector. Measured value: ~ 15 Ohm (Audi)
4. Check the injector coil for short circuit to earth. Measurement between each pin of the injector against vehicle ground. Measured value: >30 Mohm

With a special tester it is possible to check the spraying of the injectors when they are removed. It is also possible to clean them.

