



BRIEF INFORMATION

Gearbox Speed Sensor

- › Measures rotational speed of gears inside the transmission and delivers precise real-time gear speed data for optimal transmission control
- › Contactless sensing ensures long-lasting, maintenance-free performance
- › Operates reliably under extreme temperatures and high-speed conditions
- › Seamlessly integrates with ECU/TCU for smooth gear shifts and diagnostics

PRODUCT FEATURES

Application

The Gear Box Speed Sensor is a key component of the vehicle powertrain system essential for the efficiency, comfort, and reliability of modern automatic transmissions. It enables precise control of the vehicle switching behavior and contributes to reducing wear and energy losses.

Design and function

The gearbox speed sensor is typically mounted near gear output shaft or speed rotor.

It measures the rotational speed of gears inside the transmission and provides real-time data to the Engine Control Unit (ECU) or Transmission Control Unit (TCU). The rotational movement of the gear ring causes a change in

the magnetic field, which in turn generates a change in voltage in the transmission sensor. These voltage signals are transmitted from the transmission sensor to the control unit. This information is critical for gear shift timing, torque management and vehicle diagnostics.

This sensor is typically based on Hall-effect or magnetoresistive principles, ensuring accurate and contactless signal acquisition. It is designed to withstand high-speed rotation, temperature variations and electromagnetic disturbances.

FUNCTIONAL DIAGRAM

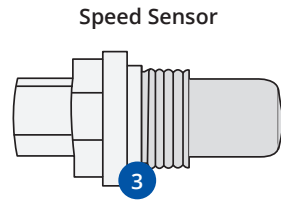
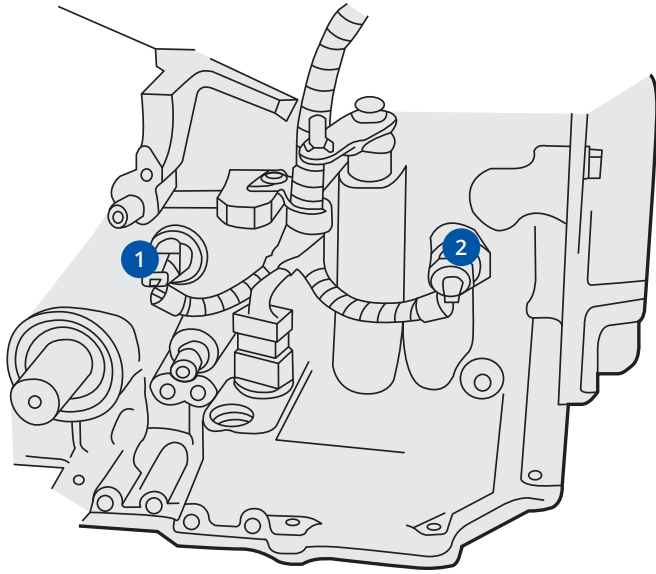

- 1 Input Speed Sensor
- 2 Output Speed Sensor
- 3 O-Ring

Depending on the type of transmission, 1 to 3 sensors are installed. In modern transmissions, speed sensors are sometimes located directly in the mechatronic module or valve body of the transmission. The input sensor is often located deeper inside the transmission and monitors the internal turbine shaft.

The output sensor measures the output shaft at the outer end of the transmission. Both provide different signal ranges corresponding to the speeds in the respective transmission range. A third sensor can also monitor intermediate shafts.

DIGITAL SIGNAL

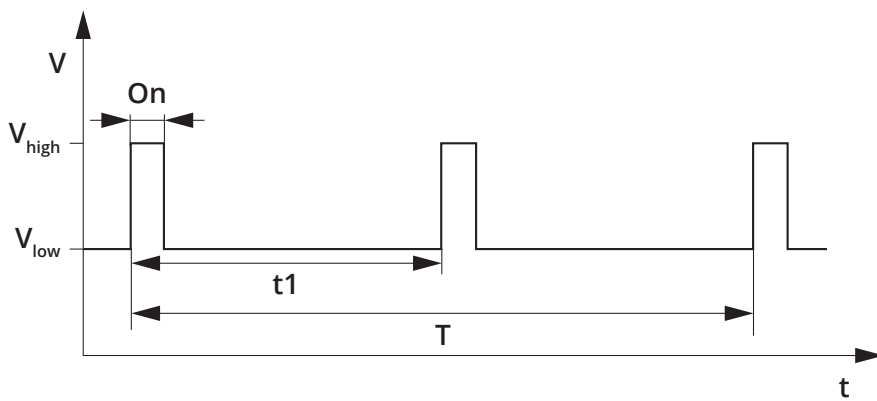

- V Voltage
- V_{low} Low level voltage
- V_{high} High level voltage
- $t1$ Pulse width
- T Signal period
- t Time

SCHEMATIC PRESENTATION MAGNETIC TECHNOLOGY

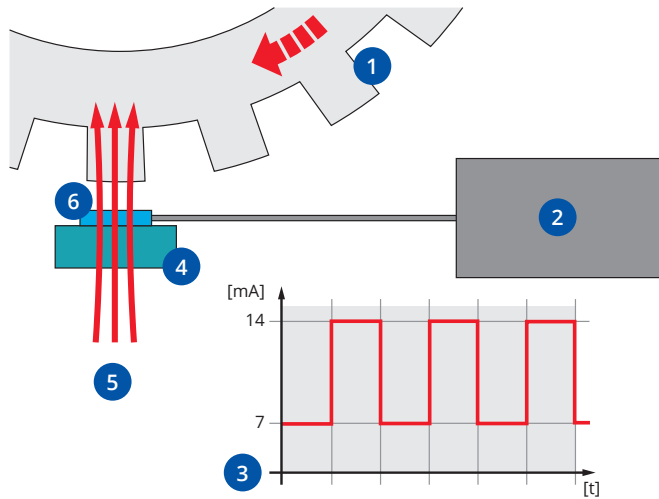

- 1 Increment wheel
- 2 ECU
- 3 Digital Signal
- 4 Permanent Magnet
- 5 Magnetic Field Line
- 6 Sensor Element

SCHEMATIC PRESENTATION HALL TECHNOLOGY

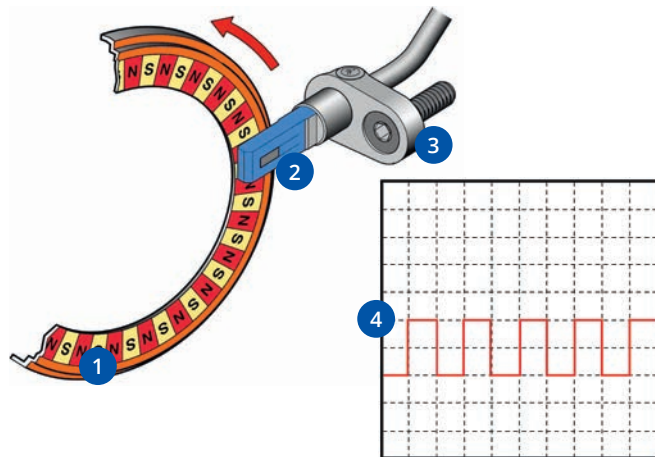

Hall sensors allow larger air gaps to respond to the smallest changes in the magnetic field.

- 1 Transmitter ring (Magnets with alternating pole directions)
- 2 Sensor
- 3 Sensor housing
- 4 Digital Signal

TECHNICAL DETAILS

Technical data

Operating voltage range	Single-voltage (4.5–24 V)
Rated voltage	12 V
Polarity reversal voltage	12 V, 60 seconds
Supply voltage	12 V
Average max. current consumption	6 to 10 mA (depending on variant)
Operating temperature	-40 °C to +150 °C
Storage temperature	-40 °C to +150 °C
Output signal	Square Wave/Pulse
Communication interface	PWM/Optional CAN
Protection class	IP 6K9K
Connector	2-pin/3-pin waterproof automotive grade
ESD	GB/T 19951
Frequency	0–10 kHz (depending on gear RPM)

Dimensional sketch

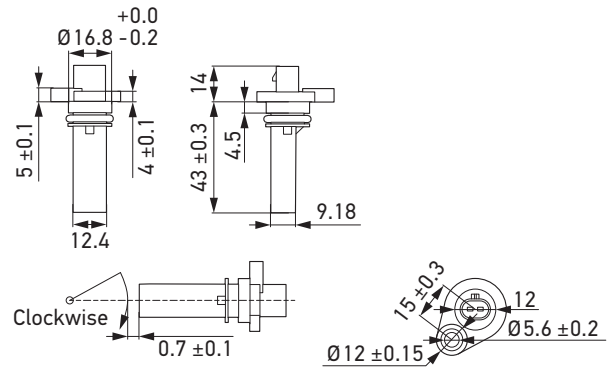

Pin assignment/electrical connection

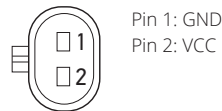

PROGRAM OVERVIEW

Product picture	Description	Part number	VPE*
	Gearbox Speed Sensor	On request	1

* Packaging unit