

## BRIEF INFORMATION

### Flat Beam 1000

- Highly efficient worklight
- Awarded with an entry in the “Green Directory” \*
- Extremely flat design

### PRODUCT FEATURES

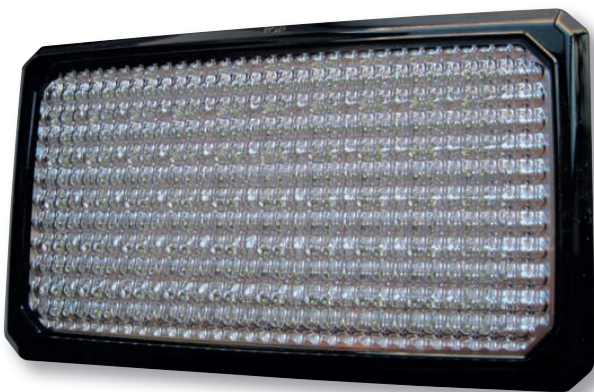

The highly efficient worklight with 60 LEDs and flat design has a power consumption of only 11 Watt. To achieve the same output with a halogen light, 70 Watt (e.g. H3) are required.

The vehicle's reduced energy consumption is good for the environment. The extremely flat design permits flexible mounting possibilities e.g. on the rear bulkhead of trucks.

The new Flat Beam 1000 with 45° illumination brings light to the near-field workspace without even tilting the worklight.

\* Prize winner for environmentally-friendly product during the Automechnika 2010 in Frankfurt.

# TECHNICAL DETAILS

## Technical data

Operating voltage 12 – 24 V multi-voltage

Power consumption 11 W

Luminous flux > 1.100 lm

## Part number

1GD 996 193-001

Mounting

1GD 996 193-011

With bracket for rear assembly / recommended inclination angle 10°

1GD 996 193-051

45° lens focuses the light directly on the floor (0° assembly)

## Technical drawing

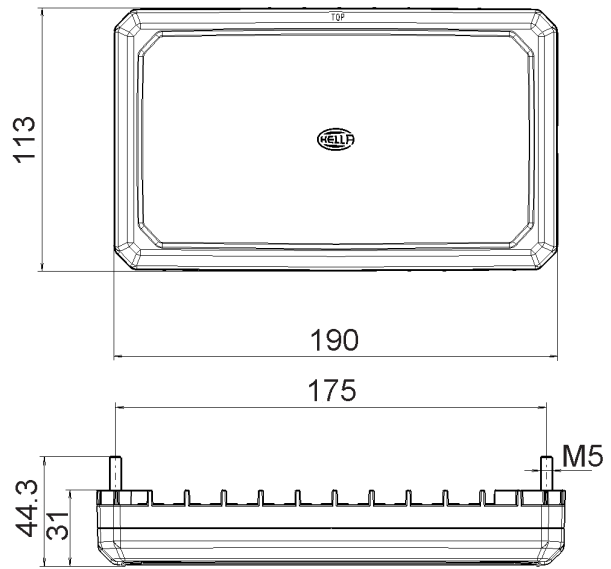

# LIGHT DISTRIBUTION

