



**ENGINE COOLING AND
VEHICLE AIR CONDITIONING**
AGRICULTURAL AND
CONSTRUCTION VEHICLES



What is thermal management?

Modern thermal management encompasses the areas of engine cooling and vehicle air conditioning. In addition to ensuring an optimum engine temperature in all operating states, the main tasks include heating and cooling of the vehicle cabin.

However, these two areas should not be considered in isolation. One unit is often formed from components of these two assemblies which influence one another reciprocally. All components used must therefore be as compatible as possible to ensure effective and efficient thermal management.

In this brochure, we would like to present you with an overview of our modern air-conditioning systems and also the technology behind them. We not only present the principle of operation, we also examine causes of failure, diagnosis options and special features.

Disclaimer/Picture credits

The publisher has compiled the information provided in this training document based on the information published by the automobile manufacturers and importers. Great care has been taken to ensure the accuracy of the information.

However, the publisher cannot be held liable for mistakes and any consequences thereof. This applies both to the use of data and information which prove to be wrong or have been presented in an incorrect manner and to errors which have occurred unintentionally during the compilation of data. Without prejudice to the above, the publisher assumes no liability for any kind of loss with regard to profits, goodwill or any other loss, including economic loss. The publisher cannot be held liable for any damage or interruption of operations resulting from the non-observance of the training document and the special safety notes. The pictures shown in this booklet were mainly provided by the companies Behr GmbH & Co. KG and Behr Hella Service GmbH.

CONTENTS

Air conditioning basics

Air conditioning check and air conditioning service	06
Air conditioning and cooling unit	07
Air conditioning circuit	08
Components of the air conditioning system	09
Repair and service	15
Removal and installation instructions	16
Fault diagnostics	18

Compressor

Removal/installation and troubleshooting of air conditioning compressors	20
Repair and replacement of air conditioning compressors	22
Compressor damage	26
Development of noise	28

Maintenance and repairs

Flushing the air conditioning system	29
Leak detection technologies	34

Compressor oils

PAG Oil	36
PAO Oil 68 and PAO Oil 68 Plus UV	38
POE Oil	40
Comparison of compressor oils	41
Product overview	42

Modern Cooling Systems

Output of the Cooling System	46
Structure of a Modern Cooling Module	47
Engine Cooling With Water	47

Cooling – A Look Back

Cooling System Earlier	48
Present State	49

Cooling Systems

The Engine Cooling System	50
Coolant radiator	51
Expansion tank	52
Radiator Cap	54
Heat exchanger	56
Intercooler	57
Oil Cooler	59
Visco® clutch	61
Visco® fans	63

Diagnosis, Maintenance and Repair

Coolant, Antifreeze and Corrosion Protection	64
Radiator Maintenance	65
Flushing the Cooling System	65
Bleeding the System When Filling It	66
→ Checking the Cooling System via a Pressure Test	66
Typical Damage	67
→ Radiator	67
→ Heat exchanger	67
Cooling System Check and Diagnosis	68
→ Engine overheats	68
→ Engine does not get warm	69
→ Heating not sufficiently hot	69
→ Flushing the Cooling System	70
→ Cleaning	70

AIR CONDITIONING OF DRIVER CABS IN AGRICULTURAL AND CONSTRUCTION VEHICLES

What started off as roofs or folding tops to protect against the weather, have nowadays become complex fully air-conditioned driver's cabs.

They offer a comfortable workplace, protected from noise, dust and other air-borne substances. However, this can only be guaranteed if they close as tightly as possible and also remain closed when the vehicle is in operation.

Clearly laid out extensively glazed cabins that are close to heat-emitting vehicle parts (engine, transmission, exhaust system) can reach temperatures of up to 60°C. The challenge of vehicle air conditioning is to keep climatic stresses for the driver as low as possible and prevent damage to health and substandard working conditions. If this is not achieved, work may not be carried out properly, accidents could occur and statutory health and safety at work regulations cannot be complied with.

Some measures for reducing climatic stress are thermal insulation of the cab walls, tinted windows, interior sun visors, forced ventilation, filtering and air conditioning of the interior. However, as space in the cabin is limited, this represents a considerable challenge. The large supply air flows required to dissipate the heat in the cabin that are cooled by the air-conditioning system must not be counterproductive by adversely affecting the health of the occupants. Owing to these requirements, some compromise is inevitable when designing the interior air conditioning.

The driver himself can also ensure that the driver's cab heats up as little as possible and cools down as quickly as possible and avoid health problems:

- Park the vehicle in the shade
- Ventilate the driver's cab if it has become overheated before setting off to cool it down
- Put the air-conditioning system briefly in air recirculation mode before setting off
- Make sure the air flow is not pointing directly at the head
- The interior temperature following cooling should be no more than 7°C below the outside temperature nor should the interior be cooled down by more than 22°C
- Observe the maintenance intervals of the cabin filter and air-conditioning system
- Clean the condenser, radiator and ventilation grille regularly



AIR CONDITIONING CHECK AND AIR CONDITIONING SERVICE

Alternating air conditioning check and air conditioning service

Air conditioning check and air conditioning service can be compared to small and large inspection:

Info box

Behr Hella Service recommendation for agricultural and construction vehicles: Perform the air-conditioning check every 12 months or 750 operating hours and air-conditioning service every 2 years or 1500 operating hours.

What should be done when?

What?	Air conditioning check	
When?	Every 12 months or 750 hours of operation	
Why?	The interior filter filters dust, pollen and dirt particles out of the air before it flows clean and cooled into the interior. Like with any other filter, the absorption capacity of this filter is limited. There is an evaporator in every air conditioning system. Condensation forms in its fins. With time, bacteria, fungi and micro-organisms settle here. For this reason, the evaporator must be disinfected regularly.	
What does it involve?	<ul style="list-style-type: none"> → Make a visual inspection of all components → Function and performance test 	<ul style="list-style-type: none"> → Interior filter replacement → If needed, disinfection of evaporator

What should be done when?

What?	Air conditioning service	
When?	Every 2 years or 1500 hours of operation	
Why?	Up to 10 % of the refrigerant escapes per year, even from a new air conditioning system. A normal process which does, however, reduce cooling capacity and threaten compressor damage. The refrigerant is freed from humidity and contaminants by the filter dryer.	
What does it involve?	<ul style="list-style-type: none"> → Make a visual inspection of all components → Function and performance test → Replace the filter-dryer → If needed, disinfection of evaporator 	<ul style="list-style-type: none"> → Refrigerant replacement → Leak test → Interior filter replacement

AIR CONDITIONING AND COOLING UNIT



Consider air conditioning and cooling as unit

Although the air conditioning system and the engine cooling system are two separate systems, they influence one another. Air conditioning system operation places additional load onto the engine cooling system and the coolant temperature rises.

The additives contained in the coolant do not only protect against frost, but also against engine overheating. The proper coolant composition increases the boiling point of the medium to above 120 °C.

An enormous performance reserve. This is particularly important in the summer, when air conditioning system and cooling system are heavily burdened by ambient temperatures and long trips. The best approach is to check the coolant during air conditioning service as well.

AIR CONDITIONING CIRCUIT

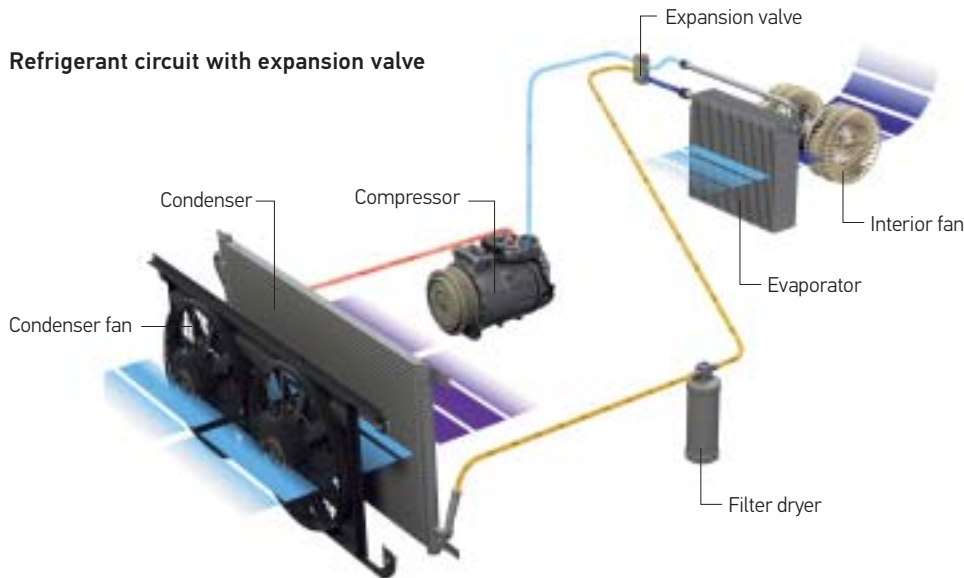

How the air conditioning system with expansion valve works

For controlling the climate in the vehicle interior, refrigerant circuit as well as coolant circuit are required. A mixture of cold and warm air allows the generation of the desired climate conditions - completely independently from outer conditions. As a result, the air conditioning system becomes an important factor for safety and driving comfort.

The individual components of the refrigerant circuit are connected by tubes and/or aluminium pipes and thus form a closed system. Refrigerant and refrigerant oil circulate in the system, driven by the compressor. The circuit has two sides:

- The section between the compressor and the expansion valve is the high pressure side (yellow/red).
- The section between the expansion valve and the compressor is the low pressure side (blue).

The gaseous refrigerant is compressed by the compressor (thereby significantly increasing its temperature) and pressed under high pressure through the condenser. This removes heat from refrigerant - it condensates and changes its state from gas to liquid.

The filter dryer, the next unit, removes contaminants and air from the liquid refrigerant as well as humidity. This ensures system effectiveness and protects the components from damage caused by contaminants.

The liquid refrigerant from the filter dryer now reaches the expansion valve.

This represents the point of separation between the high-pressure and low-pressure sections in the refrigerant circuit. The expansion valve mounted upstream of the evaporator routes liquid refrigerant to the evaporator. As the volume of refrigerant increases, it evaporates and turns to gas. This releases evaporation cooling which is absorbed by the surroundings in the interior. To achieve optimum cooling capacity in the evaporator, the refrigerant flow is controlled by the expansion valve depending on the temperature. This ensures complete evaporation of the liquid refrigerant, so that only gaseous refrigerant can reach the compressor.

COMPONENTS OF THE AIR CONDITIONING SYSTEM



Compressors

The air conditioning compressor is usually driven by the engine via a belt or ribbed V-belt. The compressor compresses and transports the refrigerant in the system. There are different designs available.

The refrigerant is sucked in as a gas at low temperature from the evaporator; it is then compressed. It is then forwarded in a gaseous state at high temperature and high pressure to the condenser.

The compressor can be dimensioned depending on the size of the system.

The compressor is filled with special oil to provide lubrication. Some of the oil circulates through the air conditioning system with the refrigerant.

Info box

Insufficient lubrication caused by leaks and related refrigerant and oil losses as well as insufficient maintenance, can lead to compressor failures (leaking shaft oil seal, leaking housing seal, bearing damage, the piston getting stuck, etc.).

Please observe that compressors are described in detail starting from page 18.



Condensers

The capacitor is needed in order to cool the refrigerant that is heated up by the compression in the compressor. The hot refrigerant gas flows into the condenser and transfers heat to the surroundings via the pipe and fins. As it cools down, the state of the refrigerant changes again from gaseous to liquid.

How it works

The hot refrigerant gas flows on top into the condenser and transfers heat to the surroundings via the pipe and fins. Due to cooling down the refrigerant exists the condenser at the lower connection in liquid state.

Info box

Due to the special installation location, failures of environmental nature can occur caused by contamination or stone chipping. Defects caused by front-impact accidents occur particularly often.

Effects of failure

A defective condenser may exhibit the following symptoms:

- Poor cooling capacity
- Failure of the air conditioning system
- Continuously running condenser fan

Causes for occurring faults can be:

- Leaks at the connections or caused by damage
- Insufficient heat exchange due to contamination

Troubleshooting

Test steps for fault elimination:

- Check condenser for contamination
- Check for leaks
- Pressure test on the high and low pressure sides



Filter dryer

The filter elements of the air conditioning system are either referred to as filter dryers or accumulators, depending on the type of system. The task of the filter dryer is to remove impurities from the refrigerant and to dehumidify it.

How it works

The liquid refrigerant enters the filter dryer, flows through a hygroscopic drying medium and leaves the filter dryer again as a liquid. The upper part of the filter dryer serves as a compensation chamber; at the same time, the lower part serves as refrigerant storage in order to compensate fluctuations in pressure in the system.

Info box

Therefore, the filter dryer must normally be renewed every 2 years or each time the refrigerant circuit is opened. Aging of the filter dryer can lead to severe defects in the air conditioning system.

Depending on its design, the filter dryer can only remove a certain amount of humidity - then the drying medium is saturated and no longer in a position to absorb further humidity.

Effects of failure

A failure of the filter dryer may exhibit the following symptoms:

- Poor cooling capacity
- Failure of the air conditioning system

Causes for the failure of the filter dryer can be:

- Aging
- Defective filter pad inside
- Leaks at the connections or caused by damage

Troubleshooting

The following steps are to be considered during troubleshooting:

- Verify maintenance intervals (every 2 years or 1500 hours of operation)
- Leak test/correct fit of the connections/damage
- Pressure test of the high and low pressure sides



Expansion valve/orifice tube

The expansion valve represents the point of separation between the high pressure and low pressure sections in the refrigerant circuit. It is installed in upstream of the evaporator. To achieve optimum cooling capacity in the evaporator, the refrigerant flow is controlled by the expansion valve depending on the temperature. As a result, complete evaporation of the liquid refrigerant is ensured and gaseous refrigerant arrives at the compressor only. Expansion valves may differ in their design.

How it works

The liquid refrigerant - arriving through the filter dryer from the condenser - flows through the expansion valve and is injected into the evaporator. The evaporating refrigerant releases evaporation cold. This causes the temperature to drop. To achieve optimum cooling capacity in the evaporator, the refrigerant flow is controlled by the expansion valve depending on the temperature. At the end of the evaporator, the refrigerant is transported through the expansion valve to the compressor. If the refrigerant temperature increases at the end of the evaporator, it expands in the expansion valve. This results in an increase of the refrigerant flow (injection quantity) to the evaporator. If the refrigerant temperature lowers at the end of the evaporator, the volume in the expansion valve decreases. As a result, the expansion valve reduces the refrigerant flow to the evaporator.

Info box

Humidity and contaminations in the air conditioning system can severely impact the functional capability of expansion valves/orifice tubes and lead to malfunctions. This means regular maintenance is important!

Effects of failure

A defective expansion valve can manifest itself as follows:

- Poor cooling capacity
- Failure of the air conditioning system

There are a number of possible causes of failure:

- Temperature problems due to overheating or icing
- Contaminations in the system
- Leaks at the component or the connection pipes

Troubleshooting

The following test steps should be followed in the case of a malfunction

- Visual inspection
- Acoustic test
- Check connection pipes for tight and correct fit
- Check components and connections for leak-tightness
- Temperature measurement on the line system
- Pressure measurement with the compressor switched on and the engine running



Evaporator

The evaporator is used to exchange heat between the ambient air and the refrigerant in the air conditioning system.

How it works

The expansion valve and/or orifice tube injects the highly pressurized liquid refrigerant into the evaporator. The refrigerant expands. The resulting evaporation cold is discharged to the environment via the large surface of the evaporator and routed to the vehicle interior through the ventilation airflow.

Info box

Contamination, humidity and insufficient maintenance can lead to evaporator defects. In order to avoid this, the air conditioning must be maintained and/or disinfected on a regular base.

Effects of failure

A defective evaporator exhibits the following symptoms:

- Poor cooling performance
- Failure of the air conditioning system
- Poor ventilation performance

Causes for failure of the evaporator can be:

- Pipes blocked in the evaporator
- Evaporator leaking (at the connection, caused by damage)
- Evaporator contaminated (air passage disturbed)

Troubleshooting

The following test steps should be considered during troubleshooting:

- Check evaporator for contamination
- Inspect evaporator for damage
- Check connection pipes for correct fit
- Leak test
- Pressure measurement with the compressor switched on and the engine running
- Temperature measurement on the input and output line



Pressure switches and switches

Pressure switches are responsible for protecting the air conditioning system against damage caused by too high or too low pressures. There are low pressure switches, high pressure switches and trinary switches. The trinary switch comprises the high pressure switch and the low pressure switch and an additional switch contact for the condenser fan.

How it works

The pressure switch (pressure monitor) is normally installed on the high pressure side of the air conditioning system. In the case that the pressure is too high (approx. 26-33 bar) it switches the power supply to the compressor clutch off. If the pressure is reduced (approx. 5 bar), it switches

Info box

Pressure switches may fail due to contacting problems, cable break or contaminations. Regular system maintenance prevents failures.

the power supply on again. If the pressure is too low (approx. 2 bar), the power supply is interrupted as well in order to avoid compressor damage due to insufficient lubrication. The third switch contact in the trinary switch controls the electrical condenser fan in order to ensure optimum refrigeration condensation in the condenser.

Effects of failure

A defective or failing pressure switch can manifest itself as follows:

- Insufficient cooling performance
- Air conditioning system without function
- Frequent switching on and off of the compressor clutch

Air conditioning system without function. There are a number of possible causes of failure:

- Contact fault at electrical connections
- Contaminations in the system
- Damage to the housing caused by vibrations or accidents

Troubleshooting

Test steps for fault diagnostics:

- Visual inspection
- Check connector block for correct fit
- Inspect component for damage
- Pressure measurement with the compressor switched on and the engine running
- Component test in the disassembled condition with nitrogen gas cylinder, pressure reducer and multimeter



Blower fan

The ventilation fan is used for ventilation the passenger car. It ensures clear visibility and a pleasant interior climate. Major pre-requisites for safe and comfortable driving.

Info box

Failure of the fan results in an uncomfortable interior climate, which has a negative impact on the driver's concentration. This represents a significant reduction in safety. Lack of ventilation can also cause the windshield to mist up. Vision limited by misted up windows is a major safety risk.



Fittings and tubes

Fittings and tubes connect the single components carrying refrigerant. The fittings are pressed onto the tube end using a special tool. This tool is available in a variety of designs.



Condenser fan

The condenser fan helps to ensure the optimal liquefaction of the refrigerant no matter what operating state the vehicle is in. It is mounted upstream or downstream of the condenser and/or engine cooling system as an additional or combination fan.

Info box

Condenser fans may fail due to electrical or mechanical damage. As a result, the refrigerant is not sufficiently liquefied anymore. The air conditioning system performance is reduced.

REPAIR AND SERVICE

Safety information/handling of refrigerant

Always wear safety glasses and safety gloves!

Under normal atmospheric pressure and at ambient temperatures liquid refrigerant evaporates so suddenly that contact with skin or eyes may cause frost damage to the tissue (risk of blinding).

- In the case of contact, rinse the affected locations with plenty of cold water. Do not rub. Immediately seek medical attention!
 - When working on the refrigerant circuit the work-place must be well ventilated. Inhalation of high concentrations of gaseous refrigerant causes dizziness and danger of suffocation. Work on the refrigerant circuit may not be performed from working pits. As gaseous refrigerant is heavier than air, it can there accumulate in high concentrations.
 - Do not smoke!
Cigarette embers can break down refrigerant into toxic substances.
 - Refrigerant must not contact open fire or hot metal. Deadly gases may be generated.
- Never allow refrigerant to escape into the atmosphere. If the refrigerant container or the air conditioning system are opened, the content discharges under high pressure. The pressure amount depends on the temperature. The higher the temperature is, the higher is the pressure.
 - Avoid any head impact on components of the air conditioning system. After paintwork, vehicles must not be heated above 75 °C (drying furnace). Otherwise, the air conditioning system must be drained first.
 - When removing the service tubes from the vehicle, the connections must not be pointed towards your body. Refrigerant residues may leak.
 - When cleaning the vehicle, the steam-jet cleaner must not be directly pointed onto parts of the air conditioning system.
 - Never change the factory setting of the adjusting screw on the expansion valve.



REMOVAL AND INSTALLATION INSTRUCTIONS

Air conditioning system

Prior to removal and/or installation of the spare part it must be verified that connections, fixings and other installation-relevant properties are identical.

When replacing components, always use new O-rings suitable for the refrigerant.

The compressor oil has a strong hygroscopic effect. Thus, the system must be kept closed if possible and/or the oil is to be filled shortly prior to closing the refrigerant circuit only.

Prior to the installation, O-rings and seals are to be greased with refrigerant oil or special lubricants in order to facilitate installation. No other greases or silicone spray may be used as this results in immediate contamination of the new refrigerant.

For every opening of the refrigerant circuit the dryer must be replaced due to its strong hygroscopic effect. If dryer or accumulator are not replaced on a regular base, the filter pad may decompose and silicate particles may be distributed in the entire system and cause severe damage.

The system connections should never remain open for an extended period of time, but should be immediately closed using caps or plugs. Otherwise, liquid would be entered together with air into the system.

In order to avoid damage to connection pipes and/or components, always use two wrenches when loosening and fastening the connections.

When routing tubes and cables make sure that no damage is possible caused by vehicles edges or other moving components.

When replacing a component of the air conditioning system, the correct oil quantity in the system is to be ensured. Oil must be refilled or drained as needed.

Prior to refilling the system, it must be checked for leak-tightness. Next, the system is to be sufficiently evacuated (approx. 30 minutes) in order to ensure that all humidity is removed from the system.



O-ring set

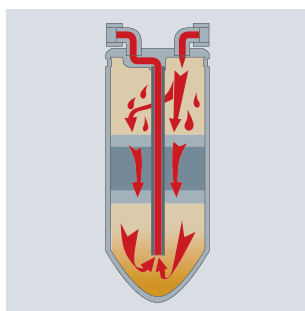

Filter dryer



Pressure gauge

After filling the refrigerant quantity specified by the vehicle manufacturer, the system is to be checked for proper function and leak-tightness (electronic leak indicator). At the same time, the high and low pressure values must be observed using pressure manometers and compared with the specified values. Compare the outflow temperature on the centre vent with the values specified by the manufacturer.

After the service connections are fitted with protective caps, the maintenance due date is to be indicated on an adhesive service label on the front cross member.

Information regarding the installation of air conditioning system compressors

Make sure that all contaminations and foreign substances are removed from the refrigerant circuit. For this purpose, the system is to be flushed prior to installing the new compressor. Depending on the level of contamination, refrigerant R134a or a special flushing solution is suitable for flushing. Compressors, dryers (accumulators), expansion valves and/or orifice tubes cannot be flushed. As it must always be assumed and cannot be ruled out that the system is contaminated (abrasion, swarf) when a compressor is defective, the system must always be flushed when this component is replaced. Make sure that no flushing solution residues remain in the system. Dry the refrigeration circuit using nitrogen as needed.

Replace the filter dryer or accumulator and the expansion valve or orifice tube.

As one and the same compressor can potentially be used for different vehicles or systems, the oil filling quantity and viscosity must be checked and/or corrected according to the manufacturer's specifications before installing the compressor. All the oil must be siphoned off and collected. The compressor must then be refilled with the entire oil quantity specified by the vehicle manufacturer (system oil quantity).

The compressor must be spun 10 x by hand before being installed to ensure the oil is distributed evenly. When installing the drive belt it must be ensured that it is aligned. Some compressors are designed for so-called "multiple applications". This means that they can be installed in different vehicles. Except the number of grooves on the magnetic clutch, there is 100% agreement with the "old part".

After compressor installation and new filling of the refrigerant circuit, the engine should first be started and operated for several minutes at idling speed.

Further specifications (instruction leaflets, manufacturer's specifications, run-in specifications) are to be separately observed.



Electronic leak indicator



PAO-Oil 68

FAULT DIAGNOSTICS

Testing the cooling capacity

In addition to test and special tools, every garage requires respective specialist knowledge, which can be acquired by

training. This applies in particular to air conditioning systems. Due to the different systems, these instructions can merely be used as guideline.

1. Start the engine. Switch through the ventilation stages.

Ventilation functioning?

Yes

No



- 2.**
- Check fuse
 - Check relays switches, wiring of all components

3. Temperature to maximum cooling

Magnetic clutch activated?

Yes

No



- 4.**
- Check wiring/electrical connections, power supply (+/-)
 - Check temperature switch/ sensor, pressure switch
 - Refrigerant filling level not correct

Proceed to 5.

5. Operate the system at maximum cooling performance and medium ventilation stage for several minutes. Air outflow temperature at the centre vent 3-8 °C.

Yes

No



- 6.**
- If the outflow temperature is too hot:
- Heating switched off?
 - Interior filter OK?
 - Check temperature switch/ sensor, thermostat (if available)
 - Check venting flaps, heating valves, condenser ventilation

7. Check low pressure (LD) and high pressure (HD) at 2000 - 2500 rpm: LD: 0.5 - 3.0 bar; HD: 6.0 - 25.0 bar; for power-regulated compressors: LD: approx. 2 bar, constant

Yes

No



- 8.**
- See table Troubleshooting

**Air conditioning
OK**

Correct evaluation of the pressure manometer display is particularly important. Here are some examples:

Air conditioning systems with expansion valve			
Low pressure	High pressure	Outflow temperature at the centre vent	Possible causes
high	high	higher, up to ambient temperature	engine overheated, condenser contaminated, condenser fan defective-incorrect direction of rotation, system overfilled
normal to occasionally low	high, occasionally	higher, possibly fluctuating	expansion valve stuck, occasionally closed
normal	high	slightly higher	filter dryer aged, condenser contaminated
high	normal to high	higher depending on bottleneck	line from condenser to expansion valve narrowed
normal	normal	higher	too much refrigerant oil in the system
normal, but inconsistent	normal, but inconsistent	higher	humidity in the system, defective expansion valve
fluctuating	fluctuating	fluctuating	expansion valve or compressor defective
normal to low	normal to low	higher	evaporator contaminated, lack of refrigerant
high	low	higher, almost ambient temperature	expansion valve stuck in opened position, compressor defective
low	low	higher, up to ambient temperature	lack of refrigerant
low pressure and high pressure are the same	low pressure and high pressure are the same	ambient temperature	Lack of refrigerant, compressor defective, fault in the electrical system

Air conditioning system with orifice tube			
Low pressure	High pressure	Outflow temperature at the centre vent	Possible causes
high	high	higher, up to ambient temperature	engine overheated, condenser contaminated, condenser fan defective-incorrect direction of rotation, system overfilled
normal to high	high	higher	system overfilled, condenser contaminated
normal	normal to high	fluctuating	humidity in the system, orifice tube occasionally blocked
high	normal	higher	orifice tube defective (cross-section)
normal	normal	higher	too much refrigerant oil in the system
normal to low	normal to low	higher	lack of refrigerant
low pressure and high pressure are the same	low pressure and high pressure are the same	ambient temperature	Lack of refrigerant, compressor defective, fault in the electrical system

REMOVAL/INSTALLATION AND TROUBLESHOOTING FOR AIR CONDITIONING COMPRESSORS

General

The air conditioning compressor is driven by the vehicle engine via a ribbed or V-ribbed belt. It compresses and transports the refrigerant in the system. There are different compressor designs available.

The refrigerant is sucked in as a gas under low pressure and low temperature from the evaporator; it is then compressed and forwarded to the condenser as a gas under high temperature and high pressure.

How it works

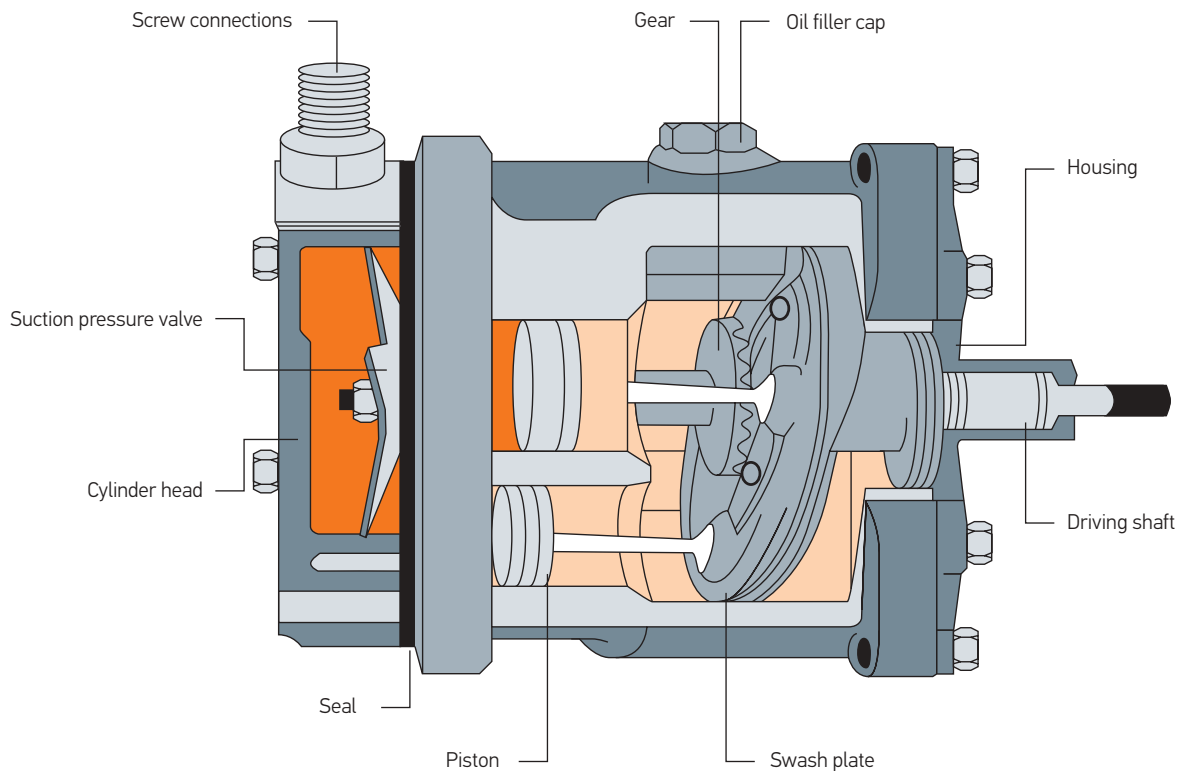

Effects of failure

A damaged or failed compressor can manifest itself as follows:

- Loss of sealing
- Development of noise
- Insufficient or no cooling performance
- Fault code is stored (automatic air conditioning)

Watch out!

Before installing a new compressor, you must check the oil quantity and the viscosity according to the manufacturer's instructions!

There are a number of possible causes of failure:

- Bearing damage caused by a defective tensioner or by wear
- Loss of sealing of the compressor shaft or of the housing
- Mechanical damage to the compressor housing
- Contact (electrical connections)
- Lack of refrigerant oil
- Lack of refrigerant
- Solids (e.g. swarf)
- Humidity (corrosion etc.)

Attention must always be paid to the following:

The entire air conditioning system must be cleaned to 100 % and the consumables must be replaced when the compressor is replaced.

Troubleshooting

Function test and pressure measurement of the system:

- Does the compressor switch on, is the connector plug securely in place, is there voltage?
- Check that the drive belt is positioned correctly, undamaged, and that there is tension.
- Check visually for loss of sealing.
- Check that refrigerant tubes are securely in place.
- Compare the pressures on the high and low pressure sides.
- Read out the fault memory.

REPAIR AND REPLACEMENT OF AIR CONDITIONING COMPRESSORS

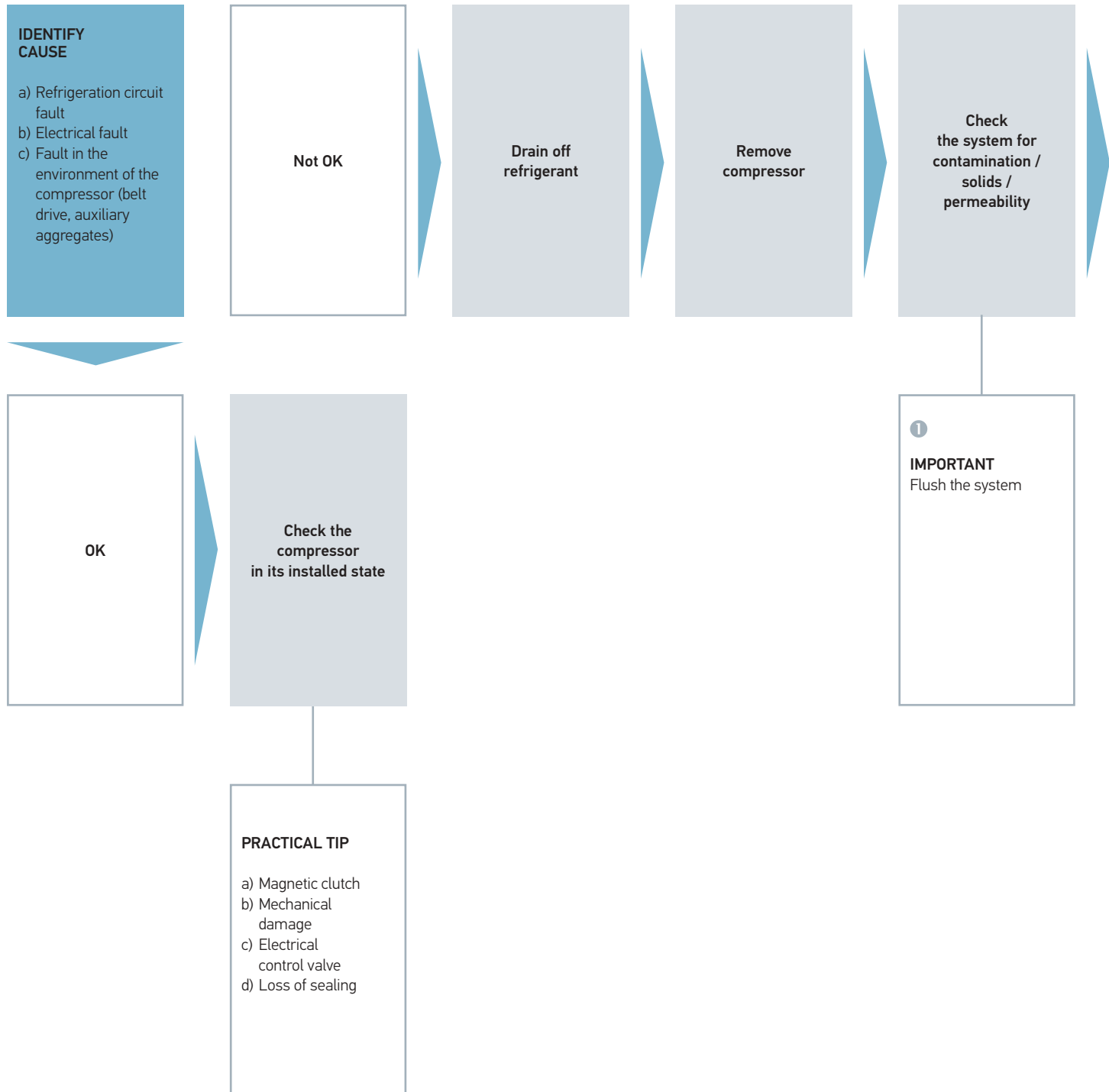

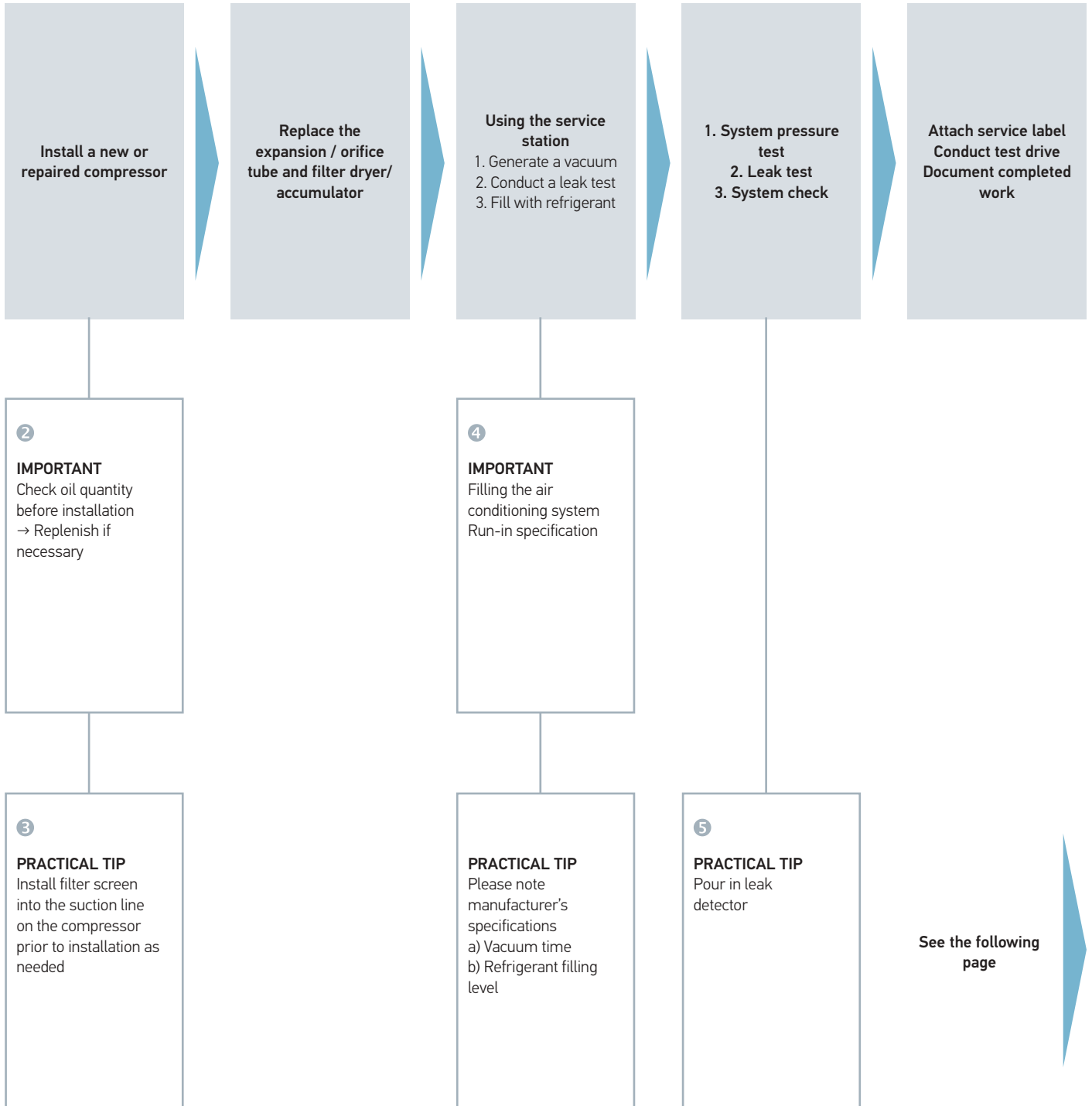

1 Thorough flushing

Dirt particles in the air conditioning circuit can only be removed by flushing the entire system thoroughly. Refrigerant R134a or a special flushing solution is suitable for flushing, depending on the level of contamination. Compressors, dryers (accumulators), expansion valves and orifice tubes cannot be flushed. As it must always be assumed and cannot be ruled out that the system is contaminated (abrasion, swarf) when a compressor is defective, the system must always be flushed when this component is replaced.

2 Refrigerant oils

Observe manufacturer's specifications and enclosed leaflet / viscosity.

1. Distribution of the oil.

There is refrigerant oil in every component of the air conditioning system. The oil is removed with the replaced component during repairs. It is therefore essential to refill the appropriate quantity of oil. The graphic below shows the average distribution of the quantities of oil within the system.

2. Observe the quantity and specification of the oil.

Before installing a new compressor or refilling refrigerant oil, the oil quantity and the viscosity according to the vehicle manufacturer's specifications must always be observed.

3. Correct quantity of system oil in the compressor.

As one and the same compressor can potentially be used for different vehicles or systems, the oil filling quantity and viscosity must be checked and/or corrected according to the manufacturer's specifications before installing the compressor. All the oil must be drained off and collected. The compressor must then be refilled with the entire oil quantity specified by the vehicle manufacturer (system oil quantity). To ensure the oil is evenly distributed, the compressor has to be spun 10 x by hand before installation. This complies with the instructions of the compressor manufacturer, Sanden – the instructions of other vehicle manufacturers must be followed in each case.

3 Compressor filter screens

Every air conditioning system must be flushed when the compressor is replaced in order to remove contamination and foreign substances from the system. If there is still contamination in the circuit despite flushing, damage can be prevented by the use of filter screens in the suction line.

General: Average distribution of oil quantity in the refrigerant circuit

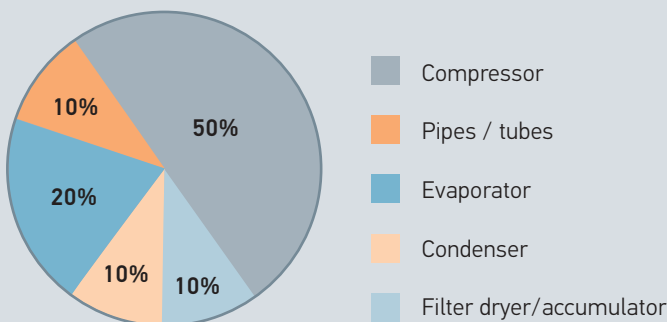

④ Filling the air conditioning system with refrigerant

Run-in specification for the compressor:

- Only fill the refrigerant using the air conditioning service station via the high pressure side service connection to prevent pressure surges of refrigerant in the compressor.
- Only the correct refrigerant in the quantity / specification defined by the vehicle manufacturer may be used.
- Set the air distribution to “centre vents” and open all centre vents.
- Set the switch for the fresh air fan to medium.
- Set the temperature to maximum cooling.
- Start the engine (without running the air conditioning) and run the engine for at least 2 minutes without interruption at idle speed.
- While at idle speed, turn on the air conditioning for approx. 10 seconds, then turn off the air conditioning for approx. 10 seconds. Repeat this procedure at least 5 times.
- Carry out a system check.

⑤ Leak detector

Compressor damage is caused by lack of refrigerant. It is therefore recommended that air conditioning maintenance is carried out regularly and that dye is added to the system, if necessary.

Important!

Replace all O-rings and wet with refrigerant oil before installation.



COMPRESSOR DAMAGE

After correction of a leak or air conditioning service the air conditioning system does not function anymore.

Case:

After the replacement of air conditioning components as well as after normal air conditioning service it happens from time to time that the air conditioning system does not function properly anymore - either immediately or shortly after the work conducted.

What is the customer complaining about?

The customer originally brings the vehicle into the garage claiming that "the air conditioning system does not cool properly anymore or "the air conditioning system does not cool at all anymore".

What does the garage do?

In such cases, the filling level of the refrigerant circuit is usually checked first. It is often found that the refrigerant amount in the system is insufficient. Depending on the system type, up to 10 % of refrigerant can diffuse from the air conditioning system within one year. However, before the system can be newly filled with refrigerant, it must be determined, whether the lack of refrigerant is caused by "natural loss" or a leak. If a leak is suspected, the system may not simply be filled with refrigerant

again. First, a search for leaks must be performed, where the air conditioning system is e.g. filled with forming gas and tested using an electronic leak indicator. Depending on the result, either the leaking component (figure 1) of the refrigerant circuit is replaced, or the filter dryer element only. Next, the system is properly evacuated and filled with refrigerant and oil according to manufacturer's specifications.

When the air conditioning system is started up again, it may occur that the compressor output is gone. If the pressure values are compared at the service station it can be observed that the values on the high pressure and low pressure side are almost identical (figure 2). It can be suspected that either the flow in the refrigerant circuit is insufficient (e.g. at the expansion valve) or that the compressor is defective. Strangely enough, there are cases, where the high pressure and low pressure values during the initial air conditioning system inspection are within the normal range, and merely the refrigerant filling level is too low; and where problems only occur after proper new filling of the air conditioning system. Evacuating and new filling can loosen dirt particles or metal abrasion, which can then deposit in the control valve (figure 3) of the compressor or in the expansion valve/orifice tube (figure 4) and cause malfunctions. This can particularly occur if the filter dryer was aged or the system was "under-filled".



Fig. 1



Fig. 2

What needs to be done?

In the case of problems the compressor should be removed and the oil should be drained. If a "greyish discoloration" (grey-green or grey-yellow if dye is used) of the oil can be detected, where fine metal particles (figure 5) are present as well, the refrigerant circuit must be properly flushed due to the foreign particles, the expansion valve and the filter dryer must be replaced, and the refrigerant circuit must be evacuated according to the specifications and newly filled with refrigerant and oil. After that, the system should function again without problems.

Is the customer sufficiently informed?

As the garage provided the customer merely with an estimate for the search for leaks and possibly for replacing the leaking component or the air conditioning service only, they may face arguments with the customer. The customer is often not ready to pay for the significant additional costs for e.g. replacing the compressor or flushing the system. For this reason, a detailed discussion with the customer, where the technical issue and risks are presented, is especially important.

What is the cause for the compressor failure?

The compressor contains the only moving components of the refrigerant circuit, and must respectively be sufficiently supplied with oil. Another task of oil in the refrigerant circuit is compressor cooling in order to avoid overheating. If a compressor is operated with an insufficient amount of refrigerant for an extended period of time (e.g. due to a leak), this results in insufficient heat dissipation and lubrication of the

compressor components, as the oil must be transported together with the refrigerant through the air conditioning system. Due to the excessive operating stress on the compressor components, metal abrasion is generated on the components, which may cause partial or complete blockage of the control valve located on the inside. The control valve blockage results in the compressor not properly working anymore. This damage can only be corrected by professional replacement of the compressor, which also includes flushing of the system. By the way, insufficient lubrication results in damage in all compressor designs. However, power-controlled compressors react particularly sensitively to insufficient refrigerant and/or oil.

Information for garages and parties accepting repairs

If the customer brings a vehicle for repair due to insufficient cooling capacity, he should be informed about a possibly required replacement of the compressor. The reason for that is that a possibly insufficient refrigerant quantity and the related lack of lubrication can cause pre-existing damage. In the case of doubt, the compressor must always be removed. If the oil is contaminated, the system must be flushed prior to replacing the compressor. If the customer request a deviating approach, the garage should record this on the bill and/or to have the customer confirm his request in writing. This Technical Information was prepared in collaboration with compressor manufacturer Sanden and is applicable to all compressor manufacturers and compressor types currently known in the market.



Fig. 3



Fig. 4



Fig. 5

DEVELOPMENT OF NOISE

Troubleshooting information in the case of noise and for compressor replacement.

The following information should always be taken into consideration when troubleshooting noise sources and prior to every compressor replacement:

- Check all retaining clamps and attachment points for breakage or cracks and possibly missing bolts or nuts. Any vibration caused may be the cause of excessive compressor noise. Observe, whether the noise changes, if you e.g. apply force onto the retaining brackets or attachment points using the assembly lever (figure 1). If a change occurs, the noises are most likely not caused by the compressor.
- Check tubes and pipes to determine, whether vibrations from the engine or pulsing refrigerant enter into the vehicle interior. For this purpose, hold them with one hand and observe possible changes in the noise (figure 2).
- Check V-belts, tensioners, tension pulleys, freewheel clutch (alternator) and belt pulleys for smooth running, play and alignment. Excessive tolerances caused by worn parts can cause noise.
- Excessive high pressure (figure 3) can cause abnormal compressor noise. If the high pressure service connection is additionally located behind a blockage in the system, the high pressure may even be higher than indicated on the manometer. In order to diagnose such a problem it is useful to measure the temperatures at the compressor.
- Excess or contaminated refrigerant causes excessive high pressure, which may cause compressor noise. The same applies to refrigerant, where the content of non-condensable gases (air) is too high.



Fig. 1



Fig. 2



Fig. 3



Fig. 4



Fig. 5

- The condenser can also be considered as cause of unusual noise. If insufficient air is routed through the condenser, the refrigerant cannot sufficiently condensate and the high pressure increases excessively. This can result in abnormal noise development. Check as well, whether the fan(s) transport(s) sufficient air through the condenser. Check the condenser and radiator fins for possible contaminations as well (figure 4).
- Often noise can be caused by contaminated expansion valves (figure 5) or orifice tubes. This can e.g. be caused by contaminations in the form of metal abrasion. This causes a reduction of the refrigerant flow and excessive high pressure occurs. "Defective" expansion valves can e.g. generate diverse "buzzing, whistling or droning noise", which can be well perceived in the vehicle interior.

FLUSHING THE AIR CONDITIONING SYSTEM

Flushing is mandatory!

The flushing of air conditioning systems is one of the most important tasks in the event of repairs or compressor damage, since it removes contaminations and damaging substances from the air conditioning circuit. Flushing is required for repairs to be performed properly and so as to avoid expensive subsequent repairs. In addition, flushing ensures warranty claims can be made against suppliers – and guarantees customer satisfaction. Compressors, expansion valves, orifice tubes and filter dryers cannot be flushed, however, and have to be bypassed by adapters during the flushing process. Valves and filters have to be replaced after the flushing process has been completed.

General information regarding flushing

- Always read the respective operating manuals, instruction leaflets, vehicle manufacturer's specifications, safety data sheets etc. carefully.
 - Before and during work, always observe the respective safety regulations, including the Technical Information "Handling refrigerants" and "Removal and installation instructions".
 - Compressors, dryers/accumulators, expansion valves and orifice tubes cannot be flushed.
 - Please make sure that all dirt or damaged components have been removed from the refrigerant circuit.
- Why flushing?**
1. In the case of compressor damage, contamination caused by metal abrasion must be removed.
 2. Acid residue caused by humidity penetration must be removed.
 3. Blockages caused by elastomer particles must be flushed out.
 4. Contaminated refrigerant or refrigerant oil must be removed without residue.
- Make sure that there is no residual flushing agent residue in the system by blowing the system components sufficiently dry with nitrogen (do not use compressed air).
 - Fill the compressor with the correct quantity/specification of oil (PAO Oil 68 available from Behr Hella Service is particularly suitable). Make sure you fill the correct quantities for the components flushed.
 - Before starting operation, spin the compressor 10 times by hand first.
 - Replace the filter dryer or accumulator and the expansion valve or orifice tube.
 - Insert a filter screen into the suction line of the compressor.

- Following correct evacuation, fill the refrigerant circuit with the prescribed quantity of refrigerant.
- Start the engine. Wait for idle stabilisation.
- Switch the air conditioning system several times on and off for 10 seconds each.
- Carry out system pressure, function and leak tests.

Flushing the air conditioning system and the components

Air conditioning systems are flushed to remove impurities and damaging substances from the refrigerant circuit. The following information has been compiled to provide support for users new to the subject of "flushing air conditioning systems" by answering important points such as:

- Why air conditioning systems need flushing at all
- What the term "flushing" means in connection with vehicle air conditioning
- What types of impurities are eliminated by "flushing" or what effects these kinds of impurities have
- Which methods of flushing exist and how they are used.

Why should a vehicle air conditioning system be flushed at all?

Defective system components (old filter dryers (figure), compressor damage etc.) can lead to dirt particles that are swept along by the refrigerant being distributed in the whole air conditioning system. If, for example, only the compressor is replaced following compressor damage, dirt particles can collect in the new compressor in no time and lead to the destruction of the newly installed system components as well as the expansion valve/orifice tube or multi-flow component – with expensive follow-on repairs the logical consequence. To avoid this, the system must always be flushed out following component





Aged filter dryer

damage that could lead to contamination of the refrigerant circuit through metal filings, rubber abrasion etc.! In the meantime, the process of flushing is also required by many vehicle or compressor manufacturers.

What does the term "flushing" mean in connection with vehicle air conditioning?

The term "flushing" is used to describe the process of removing impurities or damaging substances from the refrigerant circuit. Flushing is necessary for professional repairs to be carried out, expensive follow-on repairs to be avoided, guarantee claims against suppliers to be upheld and customer satisfaction to be ensured.

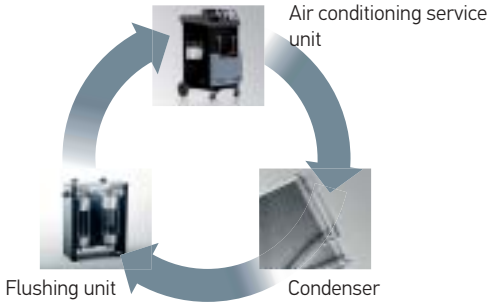
Advantages and disadvantages of the different flushing methods

		Flushing medium	
		Refrigerant	Flushing liquid
Flushing method		System components are flushed with the aid of the air conditioning service unit and an additional flushing unit with filters and adapters (both available separately).	System components are flushed using an additional flushing unit and a chemical solution. Flushing liquid residue needs to be removed with nitrogen and the system needs to be dried with nitrogen.
Advantages:		<ul style="list-style-type: none"> + No costs for the flushing agent + No disposal costs for the flushing agent + Removes oil and loose dirt particles + Method released by various vehicle manufacturers 	<ul style="list-style-type: none"> + Removes oil and loose and persistent particles + Excellent cleaning results
Disadvantages		<ul style="list-style-type: none"> - Less than optimal cleaning effect in the case of adhering contaminations - Filter insert of the flushing unit has to be replaced at regular intervals - The air conditioning service unit is not available during the procedure 	<ul style="list-style-type: none"> - Costs for the flushing agent - Disposal costs for the flushing agent
Air conditioning products		 <p>Air conditioning service unit</p> <p>Flushing unit</p> <p>Condenser</p>	

What types of impurities are eliminated by "flushing" or what effects do these kinds of impurities have?

- Abrasion when the compressor is damaged:
The material particles block expansion valves, orifice tubes or multi-flow components (condenser and evaporator).
- Humidity:
Expansion valve and orifice tubes can freeze up.
Acids that make tubes and O-rings porous can form as the result of chemical reactions between refrigerants / refrigerant oils and humidity. System components are damaged by corrosion.
- Elastomers (rubber):
The elastomer particles block expansion valves, orifice tubes or multi-flow components.
- Contaminated refrigerant oil or refrigerant:
Contaminated refrigerant or a mixture of different refrigerant oils can cause acids to form as well. The acids can make tubes and O-rings porous. Further system components can be damaged by corrosion.

1. Chemical agent (flushing liquid)

The connection pipes or system components must be flushed individually. They are flushed using a chemical agent (flushing liquid) with the aid of a universal adapter on a flushing gun. Following the flushing process, nitrogen must be used to remove the flushing medium residue from the refrigerant circuit and to dry the refrigerant circuit.

Recommendation

Maximum efficiency is achieved by combining the use of flushing liquid and nitrogen. First, even stubborn particles and hardened deposits are eliminated by flushing with flushing liquid. The subsequent blowing out with nitrogen dries the refrigerant circuit and the components again.

Disadvantage

Costs for the chemical cleaning agent and its professional disposal, as well as additional installation costs for removing and replacing pipes and components.



Abrasion with compressor damage



Contaminated oil



Flushing with flushing solution

2. Refrigerant

When flushing with refrigerant (R134a), the existing air conditioning service station is upgraded with adapter and filter elements in order to flush liquid refrigerant through the refrigerant circuit.

Disadvantage

Only loose dirt particles and oil can be removed from the system. In addition, adaptation panels are required for flushing to be carried out properly. These adaptation panels increase the costs of this method due to the additional installation and removal work involved. The service station is not available for other vehicles during the application.

Note

Whereas tube & fin and serpentine components are usually easy to clean, it is often not possible to clean components using "multi-flow" technology at all. If there is any doubt about the cleaning success where these components are involved, the components must be replaced. After the refrigerant circuit has been flushed, care must always be taken that a sufficient quantity of new oil is filled into the system.

The following quantities (% of the total oil content) serve as a reference:

- Condenser: 10 %
- Dryer/accumulator: 10 %
- Evaporator: 20 %
- Tubes/pipes: 10 %

If the above-mentioned points are not complied with, warranty may be voided.



Tube & fin



Serpentine



Multi-flow

LEAK DETECTION TECHNOLOGIES

Leak detection technologies

One of the most frequent causes of functional problems in the air conditioning system are leaks in the refrigerant circuit. These lead to an unnoticed drop in filling level and thus to a reduction in performance or even complete failure. As far as refrigerant R134a is concerned in particular, it is well known that it diffuses out of rubber pipes and connections. Since air conditioning experts cannot be sure whether there is a leak or whether the refrigerant loss is the normal loss over time, careful leak detection is a must.

The following are tested:

- All connections and pipes
- Compressor
- Condenser and evaporator
- Filter dryer
- Pressure switches
- Service connections
- Expansion valve

Three leak detection methods are recommended:

1. Dye and UV light
2. Electronic leak detection
3. Search for leaks with forming gas



Leak detection using dye

Dye

Different methods are used to add dye to the refrigerant (e.g. Spotgun dye, dye cartridges ...).

Spotgun/Pro-Shot

The exact amount of dye required is injected using the Spotgun cartridge gun or the Pro-Shot system.

Further advantage: Dye can be added when the system is full.

Leak detection lamps

Escaping dye is made visible by the UV light.

Leak detection with electronic tester/with nitrogen/through foam generation

Electronic leak detection using a leak detector

Indicates leaks through an acoustic signal. The leak detector detects halogenated gases and even detects the tiniest of leaks at points that are difficult to reach (e.g. evaporator leaks).

Leak detection using a nitrogen set

This tool can be used for leak tests – in addition to its function for drying the system. For leak tests, a filling adapter is required for the service connection as well as a tube adapter. The emptied air conditioning system is filled with nitrogen (maximum 12 bar). It is then observed over an extended period of time (e.g. 5-10 min), whether the pressure remains constant. Leaks are detected via a "hissing" sound. Otherwise, it may be sensible to make the leaky spot visible using leak detection agent. The leak detection agent is sprayed on from the outside. It forms foam at the point of the leak. Using this method, larger leaks at well accessible locations can be detected only.

Leak detection using a forming gas leak indicator

To detect leaks, the empty air conditioning system is filled with forming gas, a mixture of 95 % nitrogen and 5 % hydrogen. Using a special electronic leak indicator, the components are checked for leaks. Due to the fact that hydrogen is lighter than air, the sensor needs to be moved slowly above the suspected leak (electrical connections/components). After the end of the leak search, the forming gas can be released into the atmosphere. This leak detection method complies with Article 6, § 3 of the EU Directive 2006/40/EC.



Leak detection set forming gas



Dye



Leak detection lamp

AIR CONDITIONING COMPRESSOR OILS

Compressor oils by Behr Hella Service. Get things running like a well-oiled machine.

Oil plays an important role in the air conditioning system, no matter whether it's required when the compressor is replaced or for refilling during the air conditioning service. Like blood in the human body, the oil fulfills "vital" tasks in the air conditioning system. Decisive for safe and permanent operation of the system, however, is the use of a high-grade compressor oil. The use of low-quality or even the wrong oil leads – just like with the engine – to increased wear, premature compressor failure and perhaps loss of warranty/guarantee.

Behr Hella Service offers a vast range of PAG-, PAO- and POE-oils, that optimally match to the specific application and thus may significantly extend the life of the climate system.

Note:

The wrong selection of oil can lead to damage. Vehicle or manufacturer-specific instructions must be followed carefully.



PAG OIL

Product characteristics

PAG oils are fully synthetic, hygroscopic oils based on polyalkylene glycol. Numerous vehicle and compressor manufacturers use them in different viscosities at their plants for air conditioning systems that work with R134a refrigerant.

The new special PAG oils 46 YF and 100 YF are suitable for both of the refrigerants R1234yf and R134a.



Application/Effect

PAG oils are highly miscible with R134a (PAG oils 46 YF and 100 YF also with R1234yf) and are suitable for lubricating the air conditioning systems of most passenger and commercial vehicles.

The choice of the right viscosity is crucial when using PAG oils (PAG 46, PAG 100, PAG 150). The vehicle manufacturer's specifications and approved products should be observed.

Additional details

The disadvantage of PAG oils is that they are hygroscopic, i.e. they absorb and bind moisture from the ambient air. This is why opened oil containers must be resealed immediately and the residual oil only has a limited shelf life. This is particularly important for the fresh oil containers at the air conditioning service unit.

PAO OIL 68 AND PAO OIL 68 PLUS UV

Product characteristics

PAO-Oil 68 is not hygroscopic, i.e. unlike other oils it does not absorb moisture from the ambient air. It can be used as an alternative to the various PAG oils that are offered for R134a*. In most cases therefore, you only need to stock one type of oil, instead of three different PAG oils.

PAO oil 68 has proven itself over more than 10 years' practical use and contributes to increased air-conditioning performance. It has no deleterious effect on the components of the air conditioning circuit. The same applies to its use in air-conditioning service stations (confirmed by the manufacturer on the basis of the sealed tube test described in the ASHRAE 97 standard).

The oil is available without (PAO Oil 68) or with added contrast agent (PAO Oil 68 Plus UV).

The use of PAO oil 68 and PAO oil 68 Plus UV in compressors from Behr Hella Service is also fully guaranteed.

(* Except electric compressors)



Application/Effect

PAO Oil 68

The molecules of the PAO Oil 68 adhere to all surfaces in the system, force out other molecules and remain as a thin layer on the inner surface of the system components. Due to the fact that the molecules do not try to connect to each other, this oil layer is just one molecule "thick". Unlike many other oils, there is no risk of oil collecting in the evaporator and the associated deterioration in cooling performance when PAO il 68 is used. Due to the fact that PAO Oil 68 only slightly connects to the refrigerant, only a small part of the oil circulates through the system. The rest stays where the oil is actually needed – in the compressor.

An oil film in the components improves the seal and/or reduces the friction between the moving parts in the compressor. This reduces the operating temperature and the wear. This plays an important role in the operating safety and reduction of noise and also ensures lower run-times and less energy consumption by the compressor.

PAO-Oil 68 Plus UV

PAO Oil 68 Plus UV has the same advantageous properties as PAO Oil 68. It is additionally enhanced with a concentrated, highly effective contrast agent that is used for UV leak detection. The advantage of the low Vol %-concentration of the contrast agent is that all the properties of the oil are retained and there are no negative effects on system components or service units whatsoever.

To achieve a sufficient effect during troubleshooting, 10 Vol % of the system oil quantity are already quite adequate. This corresponds e.g. to only 18 ml PAO Oil 68 Plus UV when the total system oil quantity is 180 ml.

Of course, PAO Oil 68 Plus UV can also be used for filling the whole system without there being any negative effects.

Additional details

Can PAO Oil 68 be used for conversions?

Is PAO Oil 68 compatible with other oils?



PAG and PAO Oil 68 mixed

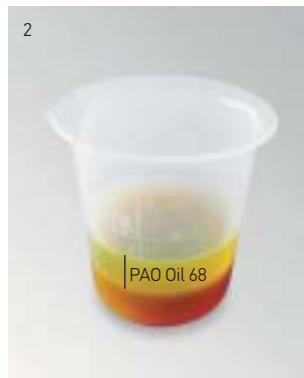

PAG and PAO Oil 68 separated

PAO Oil 68 doesn't have any harmful effects on fluoroelastomer materials, such as hoses.

Since PAO Oil 68 is compatible with many other lubricants and refrigerants, PAO Oil 68 can be used both for refilling and to replace the whole system oil capacity. Due to the independent molecular structure and density, PAO Oil 68 mixes to a certain extent with other oils, but separates from them again when it "comes to rest", and does not enter into a longer-term compound.

This guarantees that the necessary viscosity of the oils is maintained and there is no change in the overall viscosity (see Figs 1 and 2). Thanks to its unique combination of highly refined, synthetic oil and special performance-enhancing additives, PAO Oil 68 has a very high operating range (-68 to 315°C).

How was PAO Oil 68 Plus UV tested?

PAO Oil 68 Plus UV was tested by the manufacturer and independent institutes. Thus, for example, chemical stability was tested in connection with the refrigerant and different O-ring materials on the basis of the so-called "sealed tube test", as per the ASHRAE 97 standard.

All the tests showed a positive result, confirming that negative effects on components in the vehicle air conditioning system or the air conditioning service station can be excluded. Thus PAO Oil 68 Plus UV can be filled directly into a component e. g. the compressor, or via the air conditioning service station into the refrigerant circuit.

Can PAO Oil 68 be used where there are humidity problems?

PAO Oil 68 is not hygroscopic, i.e. unlike other oils it does not absorb humidity from the ambient air. This means that by simply using PAO Oil 68, humidity problems such as e.g. components icing up or acids being formed, can be counteracted. The application possibilities and the storage ability of PAO Oil 68 are much higher than with conventional oils.

Special features and properties?

- No risk of oil collecting in the evaporator and the associated deterioration in cooling performance
- An oil film in the components improves the seal
- Reduction of the friction between the components
- Reduced energy consumption of the compressor
- Unique combination of highly refined, synthetic oil and special performance-enhancing additives
- Very large operating temperature range (-68 to 315°C)
- Low Vol %-concentration of the highly active contrast agent PAO Oil 68 Plus UV, which means protection and reduced wear of the system components and service units

POE OIL

Product characteristics

Electric air conditioning compressors in hybrid vehicles are powered by an internal electric motor that operates in the high voltage range. The compressor oil in these compressors comes into contact with the electric motor coil, amongst other things.

As such, it has to satisfy particular requirements:

- It must not have any adverse effect on the materials used in the compressor.
- It must be resistant to electrical short circuits to a certain degree.

The POE Oil offered by Behr Hella Service satisfies these requirements.



Application/Effect

- Can be used on all hybrid vehicles with electrical compressor that are filled with POE Oil at the factory.
- Bottled in spotgun cartridges, which gives it maximum protection against moisture (Problem: POE Oil is hygroscopic).

Additional details

- Using the spotgun (cartridge press), it can either be filled straight into the vehicle (with the aid of an adapter hose with low pressure connection) or into the oil tank on the air-conditioning service unit.
- Spotgun cartridge 120 ml.
- Each individual cartridge is sealed in an aluminium sachet
- The aluminium sachet also contains a small bag of desiccant to provide maximum protection against moisture

COMPARISON OF OILS

Type of oil	Application	Remark
PAG Oils for refrigerant R134a	Different grades of PAG Oil with different flow properties (viscosities) are available for use with refrigerant R134a. As PAG Oils are hygroscopic, cans do not have a long shelf life once opened.	Standard PAG Oils are not suitable for refrigerant R1234yf or for electrically powered air conditioning compressors
PAG Oil YF for refrigerant R1234yf	Different PAG oils with different flow properties (viscosities) are still available for use with refrigerant R1234yf. What makes these PAG oils from Behr Hella Service so special, is that they are not only suitable for use with R1234yf, but can also be used with the refrigerant R134a. As PAG Oils are hygroscopic, cans do not have a long shelf life once opened.	PAG oil YF is suitable for both of the refrigerants R1234yf and R134a
PAO Oil for refrigerant R134a and other refrigerants	Can be used as an alternative to the various PAG oils that are offered for R134a (has the advantage of not being hygroscopic, i.e. unlike other oils, it does not absorb moisture from the ambient air). The 3 different grades of PAO Oil that Behr Hella Service offers (AA1, AA2 und AA3) can be used in conjunction with numerous different refrigerants (see product overview). At present, however, the PAO Oils offered by Behr Hella Service have not yet been approved for use with R1234yf, nor for use in electric compressors in hybrid vehicles.	
POE Oils for refrigerant R134a	Can be used on all hybrid vehicles with electrical compressor that are filled with POE Oil at the factory (some electrically powered compressors for hybrid vehicles are also filled with special PAG Oil at the factory).	Not suitable for refrigerant R1234yf

PRODUCT OVERVIEW

Product	Application	Compressor type	Refrigerant	Viscosity Class	Content	Part number
PAG Oil (can)	Vehicle air conditioning systems*	All types**	R134a	PAG I (ISO 46)	240 ml	8FX 351 213-031
		All types**	R134a	PAG II (ISO 100)	240 ml	8FX 351 213-051
	Vehicle air conditioning systems*	All types**	R134a	PAG III (ISO 150)	240 ml	8FX 351 213-041
PAG Oil (spotgun cartridge)	Vehicle air conditioning systems*	All types**	R134a	PAG I (ISO 46)	240 ml	8FX 351 213-061
		All types**	R134a	PAG II (ISO 100)	240 ml	8FX 351 213-081
	Vehicle air conditioning systems*	All types**	R134a	PAG III (ISO 150)	240 ml	8FX 351 213-071
PAG Oil YF	Vehicle air conditioning systems*	All types**	R1234yf, R134a	PAG I (ISO 46)	240 ml	8FX 351 213-121
	Vehicle air conditioning systems*	All types**	R1234yf, R134a	PAG II (ISO 100)	240 ml	8FX 351 213-131
PAO Oil 68	Vehicle air conditioning systems*	All types** (except impeller type)	R134a, R413a, R22, R12	AA1 (ISO 68)	500 ml	8FX 351 214-031
				AA1 (ISO 68)	1.0 l	8FX 351 214-021
				AA1 (ISO 68)	5.0 l	8FX 351 214-101
	Refrigerator trucks (fresh product vehicles)	Piston compressors**	R134a, R507a, R500, R12			
	Refrigerator trucks (frozen product vehicles)	Piston compressors**	R507a, R502, R22			

Product	Application	Compressor type	Refrigerant	Viscosity Class	Content	Part number
	Vehicle air conditioning systems*	All types** (except impeller type)	R404a, R407c, R401b, R401c, R409a, R409b	AA2 (ISO 32)	1.0 l	8FX 351 214-061
	Refrigerator trucks (fresh product vehicles)	Piston compressors**	R404a, R407c, R409b			
	Refrigerator trucks (frozen product vehicles)	Piston compressors**	R404a, R407c, R402a, R403a, R408a			
	Vehicle air conditioning systems*	Impeller-type compressors****	R134a, R413a	AA3 (ISO 100)	1.0 l	8FX 351 214-081
PAO Oil 68 Plus UV	Vehicle air conditioning systems*	All types** (except impeller type)	R134a, R413a, R22, R12	AA1 (ISO 68) AA1 (ISO 68) AA1 (ISO 68)	500 ml 1.0 l 5.0 l	8FX 351 214-201 8FX 351 214-211 8FX 351 214-221
	Refrigerator trucks (fresh product vehicles)	Piston compressors**	R134a, R507a, R500, R12			
	Refrigerator trucks (frozen product vehicles)	Piston compressors**	R507a, R502, R22			
	Vehicle air conditioning systems*	All types** (except impeller type)	R404a, R407c, R401b, R401c, R409a, R409b	AA2 (ISO 32)	1.0 l	8FX 351 214-261
	Refrigerator trucks (fresh product vehicles)	Piston compressors**	R404a, R407c, R409b			
	Refrigerator trucks (frozen product vehicles)	Piston compressors**	R404a, R407c, R402a, R403a, R408a			
	Vehicle air conditioning systems*	Impeller-type compressors****	R134a, R413a	AA3 (ISO 100)	1.0 l	8FX 351 214-281
POE Oils	Hybrid vehicles	Electric compressors	R134a		120 ml	8FX 351 213-111

* Passenger cars, trucks, agricultural and construction machinery

** Except electric compressors



ENGINE COOLING FOR AGRICULTURAL AND CONSTRUCTION VEHICLES

What originally started as a relatively simple cooling system has now become a highly-complex thermal management system. The engine cooling modules of modern tractors and machines contain several components: In addition to the coolant radiator for the engine, they contain the heat exchangers of the air-conditioning system, charge air, transmission, fuel system and hydraulics.

However, larger radiators are inevitably required to meet the increasing demands placed on engines, which conflicts with the current trend towards designing compact vehicles. Slanting hoods for improved visibility, a large lock for maximum maneuverability and additional space in which to mount the front hydraulic system are thus required. This considerably restricts the available space for the radiator components.

In order also to provide the required cooling performance with limited package space, the air flow rate, i.e. the flow velocity of the air, must be increased. However, the in-line arrangement of heat exchangers provides considerable resistance to the flow of cooling air and therefore reduces the air flow rate. The radiator fan must therefore produce a greater output and this can be up to 10 percent of the rated output of the vehicle. In order to achieve the necessary cooling output, an unrestricted air flow through the cooler and heat exchanger is especially important.

When carrying out work such as mowing, mulching or chopping, a huge quantity of dust and dirt is often produced. This dust and dirt is drawn in by the cooler as the high flow velocity of the cooling air produces a powerful vacuum effect. The intake grille and surface of the cooler become heavily soiled as a result. This leads to a reduced cooling output accompanied by higher operating temperatures of the engine, transmission and hydraulic system. This also leads to a reduction in the output of the air-conditioning system. In extreme cases, there is even a risk of engine damage.

Cooling systems with Visco® fans are normally used in agricultural and construction vehicles. The advantage of these fans is that they only run at full torque or full speed if a high cooling output is required. In this case, the fan speed is controlled via the Visco® fan drive. Proportionally however, the power required by a Visco® fan is far greater than the resulting increase in speed. The engine output doubles for only a 25% increase in fan speed, for example.

The fan speed also increases when soiling occurs in the area of the cooling system, which inevitably leads to an increase in fuel consumption.

However, the rate of the air flow depends on the position of the fan blades and not the fan speed. Fans equipped with variable blade angle adjustment have recently been introduced in cooling systems. An effect similar to increasing the speed can be produced by changing the blade angle. The increase in engine output associated with this is however less than it would be if the speed were increased.

As has been established, regular cleaning of the cooling system components is especially important. To do this effectively and efficiently, the vehicle features various "folding mechanisms" which allow the components to be accessed more easily. To minimize soiling and improve cleaning, the intake areas in the radiator grille are sufficiently sized and equipped with perforated metal sheets and radiator screens. The heat exchanger and intake areas can be cleaned automatically by reversing the air flow. During this procedure, the fan is "changes over" for a specific period, i.e. it blows air out instead of drawing it in. Dust and dirt is once again expelled to the surroundings thus cleaning the surfaces of the cooler, heat exchanger and ventilation grille.

TASKS PERFORMED BY THE COOLING SYSTEM

All heat produced by an engine and the systems dependent on it must be removed. Nowadays, the operating temperature of an engine can only have a small tolerance in order to monitor the operation and ambient temperature (engine and interior). An increased operating temperature can adversely affect the emission values. This can lead to a faulty engine control.

Additionally, a cooling system must warm the passengers in winter and cool them in summer with engine types such as direct injection, diesel and petrol engines that produce low quantities of heat. All those factors need to be taken into account when a thermal management system is developed. Moreover, the requirement for greater performance and efficiency in small installation spaces also exists.



STRUCTURE OF A MODERN COOLING MODULE

A typical example of a modern cooling module. The module consists of coolant radiator, engine oil cooler, condenser, transmission oil cooler, power steering cooler and condenser fan.

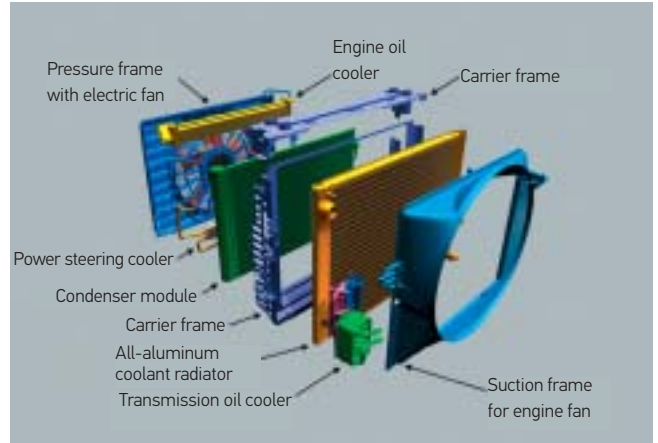

ENGINE COOLING WITH WATER

The temperatures generated during combustion of the fuel (up to 2,000°C) are detrimental to engine operation. Therefore, the engine is cooled down to operating temperature. The first kind of cooling with water was thermosiphon cooling. The heated, lighter water rises into the upper part of the radiator through a manifold. It is cooled by the airstream, then sinks down and flows back to the engine. This cycle continues for as long as the engine is running. Cooling was supported by the fan, but regulation was not possible. Later, a water pump accelerated the water circulation.

Weak points:

- Long warm-up time
- Low engine temperature during the cold season

As engines developed, cooling water regulators (i.e. thermostats) were used.

The water circulation through the radiator is regulated in dependence on the cooling water temperature. In 1922, this was described as follows: "The purpose of these devices is quick engine heating and prevention of cooling down of the engine." These were in fact thermostat-controlled cooling systems with the following functions:

- Short warm-up time
- Keeping operating temperature constant

COOLING SYSTEM EARLIER

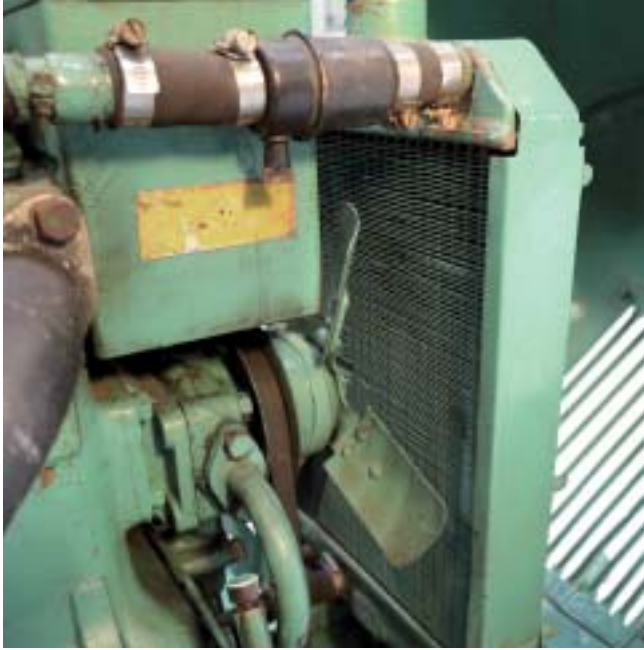

Cooling System Earlier

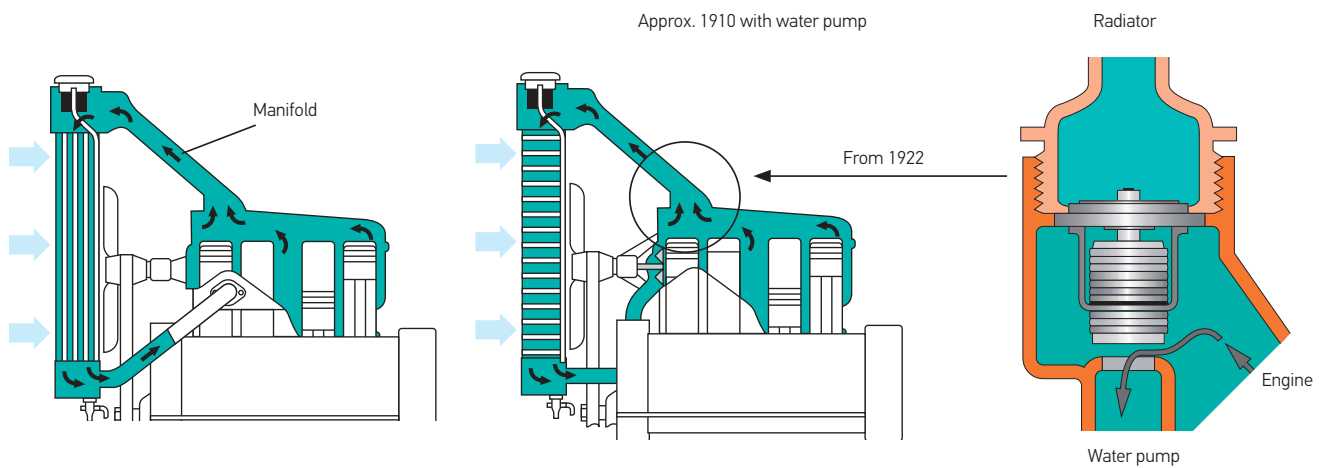

PRESENT STATE



Cooling system today

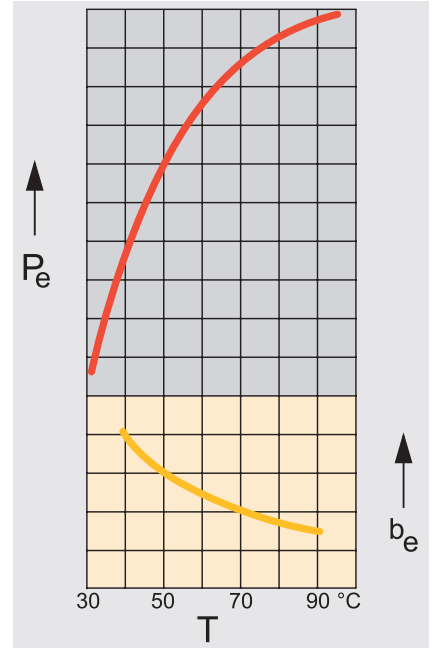

P_e = Power
 b_e = Fuel consumption
 T = Engine temperature

The thermostat was a decisive improvement and enabled a "short-circuited" coolant circulation. While the desired engine operation temperature is not reached, the water does not run through the radiator, but by-passes it and returns to the engine. That control system has remained the basis of all systems, right up to today.

The influence which the engine temperature has on performance and fuel consumption is shown in the diagram below. However, today the correct operating temperature of the engine is not only important with regard to performance and fuel consumption, but also for low emission of pollutants.

Engine cooling uses the fact that pressurized water does not boil at a temperature of 100°C, but between 115°C and 130°C. The cooling circuit is under a pressure of between 1.0 bar and 1.5 bar. We are referring to a closed cooling system. The system has an expansion tank which is only around half filled. The cooling medium is not just water, but a mixture of water and coolant additive. A coolant which provides antifreeze protection, has a higher boiling point and protects the engine's light metal parts against corrosion.

THE ENGINE COOLING SYSTEM

We all know that the engine compartment has become pretty crowded and therefore a considerable amount of heat is produced which needs to be dissipated. The cooling of the engine compartment places high demands on modern cooling systems and this has led to considerable progress in the area of cooling technology in recent times.

The demands placed on the cooling system are:

- Short warm-up phase
- Fast interior heating
- Low fuel consumption
- Longer service life of the components

All engine cooling systems are based on the following components:

- Coolant radiator
- Thermostat
- Coolant pump (mechanical or electric)
- Expansion tank
- Cables
- Engine fan (V-belt driven or Visco®)
- Temperature sensor (engine control/indicator)

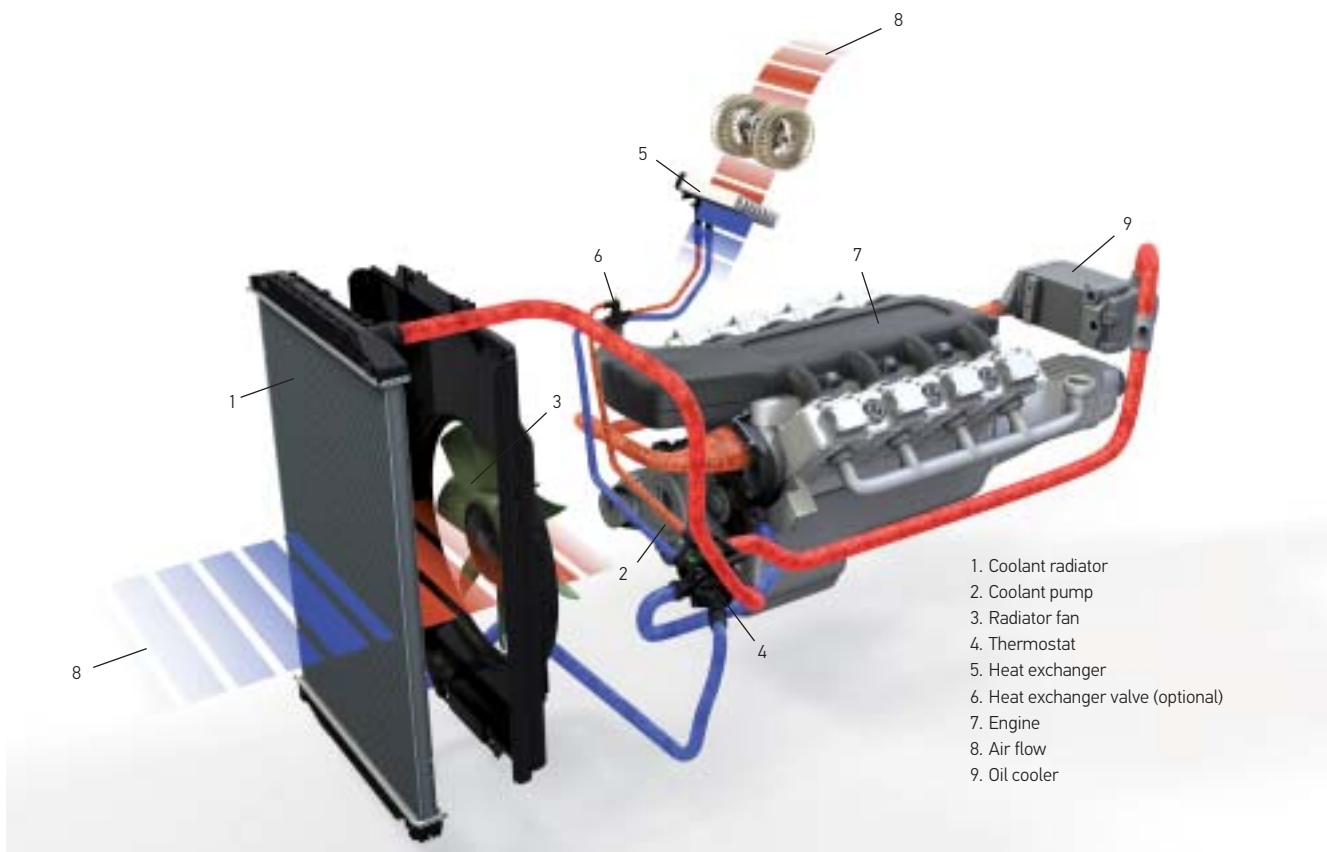

COOLANT RADIATOR

General

Coolant radiators are installed in the air flow at the vehicle front, with different designs available. They have the task of dissipating heat produced by combustion in the engine and absorbed by the coolant. Other coolers, e.g. for automatic transmission, may be found in or on the coolant radiator.



Design/Function

The most important component of a coolant module is the coolant radiator. It comprises the radiator core and water tank with all the necessary connections and fastening elements.

The radiator core itself is made up of the radiator matrix – a tube/fin system – the tube header and the core covers. Conventional coolant radiators have a coolant tank made of glass-fiber reinforced polyamide which has a seal fitted and is flanged before being placed on the tube header. The current trend is moving towards all-aluminum radiators, which tend to weigh less and have a shallower installation depth. In addition, they are 100 % recyclable.

The coolant is cooled down by means of the cooling fins (network). The external air flowing through the radiator matrix withdraws heat from the coolant.

In terms of design, a distinction is made between downflow and crossflow radiators. In the case of downflow radiators, the water enters the radiator at the top and emerges at the bottom. In the case of crossflow radiators, the coolant enters at one side and emerges at the other. If the input and output pipes of the crossflow radiator are on the same side, the water tank is divided. Coolant then flows through the radiator, in opposite directions in the upper and lower parts. Crossflow radiators are lower and are most commonly used in passenger cars.



Effects of failure

A faulty radiator can become noticeable as follows:

- Poor cooling performance
- Increased engine temperature
- Permanent radiator fan operation
- Poor air-conditioning system performance

These are possible causes:

- Loss of coolant caused by damage to the radiator (gravel throw, accident)
- Loss of coolant due to corrosion or leaky connections
- Poor heat exchange caused by external or internal contamination (dirt, insects, limescale deposits)
- Contaminated or old coolant



Troubleshooting

Test steps towards recognizing faults:

- Check the coolant radiator for outer soiling, clean with reduced compressed air pressure or a water jet if necessary.
Do not get too close to the radiator fins
- Check the radiator for external damage and leaks (hose fittings, beading, fins, plastic housing)
- Check coolant for discoloration/soiling (e.g. from oil caused by faulty gasket) and check antifreeze content
- Check coolant flow (blockage by foreign materials, sealing agents, limescale deposits)
- Measure the temperature of the coolant as it enters and leaves the radiator using an infrared thermometer



EXPANSION TANK

General

The expansion tank in the cooling system is usually made of plastic and receives the expanding coolant. It is normally installed in such a way that it represents the highest point in the cooling system. It is transparent to allow the coolant level to be checked, and has "min" and "max" markings. In addition, an electronic level sensor can be installed. Pressure compensation in the cooling system is achieved by means of the valve in the cap of the expansion tank.



Design/Function

An increase in coolant temperature leads to an increase in pressure in the cooling system because the coolant expands. This increases the pressure in the expansion tank; the pressure relief valve in the cap then opens and allows air to escape.

When the coolant temperature falls to a normal level, a vacuum is generated in the cooling system. Coolant is sucked back out of the tank. This in turn creates a vacuum in the tank. As a result, the vacuum compensation valve in the cap of the tank opens. Air flows into the tank until the pressure is equalized.

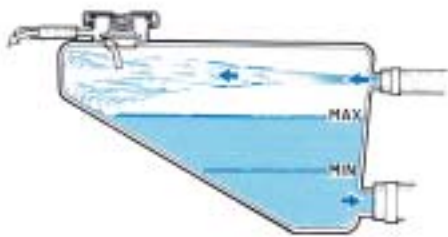

Effects of failure

The following are signs that the expansion tank or cap is faulty:

- Loss of coolant (leak) at various system components or the expansion tank itself
- Increased coolant and/or engine temperature
- Expansion tank or other system components are cracked/burst

These are possible causes:

- Excess pressure in the cooling system due to a faulty valve in the cap
- Material fatigue

Troubleshooting

Test steps towards recognizing faults:

- Check the level of coolant and the antifreeze content
- Check whether the coolant is discolored/soiled (oil, sealant, limescale deposits)
- Check the thermostat, radiator, heat exchanger, hoses and connections for leaks and check function
- Burst test the cooling system if necessary (pressure test)
- Make sure no air is trapped in the cooling system, bleed the system according to vehicle manufacturer's specifications if necessary.

If all the above points are carried out without complaint, the cap on the expansion tank should be replaced. It is very difficult to test the valve in the cap.

RADIATOR CAP

General

Frequently overlooked, but nonetheless important: the radiator cap.

In addition to the task of providing a gas-tight seal for the filling opening in the radiator or expansion tank, it also has to ensure that no excessive overpressure or vacuum builds up in the cooling system.

For this purpose, the filler cap is equipped with a vacuum and a pressure relief valve. The pressure relief valve serves to raise the pressure by about 0.3-1.4 bar. In connection to this, the boiling point of the coolant increases to 104-110°C, and the performance of the cooling system is improved. During cooling, a partial vacuum would form if the system were hermetically sealed. The task of the vacuum valve is to prevent this happening.



Design/Function

High coolant temperature results in the pressure in the cooling system rising, because the coolant expands. The coolant is pressed into the tank. The pressure in the tank rises. The pressure relief valve in the cap opens and lets air escape. When the coolant temperature falls to a normal level, a vacuum is generated in the cooling system. Coolant is extracted from the tank. This causes a vacuum in the tank. Consequently, the vacuum compensation valve in the tank cap opens. Air flows into the tank until the pressure is equalized.



How to open the radiator filler cap

- Let the cooling system cool down until the coolant temperature is below 90 °C
- When the engine is hot, the cooling system is pressurized
- A sudden opening of the cooling system can lead to scalding!
- Open the coolant cap to the safety catch, in screwed-on versions ½ turn, and let off overpressure
- Wear safety gloves, safety goggles and protective clothing!



Functional test

The proper functioning of the valve of the radiator cap can be tested with a suitable testing device (follow manufacturer's instruction).

1. Determine opening pressure by increasing the pressure.
2. The vacuum valve must be seated on the rubber seal, must be easy to lift and spring back after release.

Behr Hella Service recommends to replace the radiator cap when the radiator is exchanged.



HEAT EXCHANGER

General

The heat exchanger is installed in the heating box of the vehicle interior and has coolant flowing through it. The interior air is routed through the heat exchanger and heated.

Design/Function

As is the case with the coolant radiator, the heat exchanger consists of a mechanically connected system of tubes/fins. Nowadays, they also tend to be made entirely of aluminum. Coolant flows through the heat exchanger. The flow quantity is usually controlled by mechanically or electrically controlled valves. The interior air is heated up via the cooling fins (network) of the heat exchanger.



The air flow produced by the cabin fan or the airstream is routed through the heat exchanger which has hot coolant flowing through it. This heats up the air which is returned to the vehicle cabin.

Effects of failure

A faulty or poorly working heat exchanger can become noticeable as follows

- Poor heating performance
- Loss of coolant
- Odor build-up (sweet)
- Fogged windows
- Poor air flow rate

These are possible causes:

- Insufficient exchange of heat due to external or internal contamination (corrosion, coolant additives, dirt, limescale deposits)
- Loss of coolant through corrosion
- Loss of coolant through leaky connections
- Soiled cabin filter
- Contamination/blockage in the ventilation system (leaves)
- Faulty flap control

Troubleshooting

Test steps towards recognizing faults:

- Watch out for smells and windows fogging
- Check cabin filter
- Check heat exchanger for leaks (hose connections, beading, mesh)
- Watch out for contamination/discoloring of the coolant
- Check coolant flow (blockage through foreign matter, limescale deposits, corrosion)
- Measure coolant inlet and outlet temperature
- Watch for blockages/foreign matter in the ventilation system
- Check flap control (recirculated air/fresh air)

INTERCOOLER

General

More performance throughout the speed range, lower fuel consumption, improved engine efficiency, lower emission values, reduced thermal load on the engine – there are a variety of reasons to cool the combustion air of supercharged engines with intercoolers.

Basically, a distinction must be made between two types of cooling. Direct charge-air cooling, where an intercooler is installed in the vehicle front-end area and is cooled by ambient air (airstream), and indirect charge-air cooling, where coolant flows through the intercooler and discharges heat.



Design/Function

In terms of structural design, the intercooler corresponds to the coolant radiator.

In the case of an intercooler, the medium to be cooled down is not coolant, but rather compressed hot air (up to 150°C) coming from the turbocharger.

Basically, heat can be withdrawn from the charge air by external air or the engine coolant.

The charge air enters the intercooler and, in the case of direct intercooling, has the airstream flow through it and has cooled down by the time it reaches the engine intake tract.

In the case of a coolant-cooled intercooler, the cooler can be installed in almost any position, with the smaller design volume representing a great advantage. Thus, for example, in the case of indirect intercooling, the coolant-cooled intercooler and the intake tract can form one unit. Without an additional cooling circuit, however, the temperature of the charge air can only be

reduced to near the coolant temperature. With the aid of a separate intercooler coolant circuit independent of the engine coolant circuit, the efficiency of the engine can be further increased by increasing the air density. A low-temperature coolant radiator and a charge air coolant radiator are integrated into this circuit.

The waste charge air heat is first transferred to the coolant then channeled through a low-temperature coolant radiator and out into the ambient air.

The low-temperature radiator is housed in the vehicle front-end. Since the low-temperature radiator requires significantly less space than a conventional air-cooled intercooler, this solution creates free space in the front-end. In addition, the voluminous charge air lines are no longer required.

Schematic representation



Direct intercooling



Indirect intercooling /
Intake manifold with integrated
intercooler

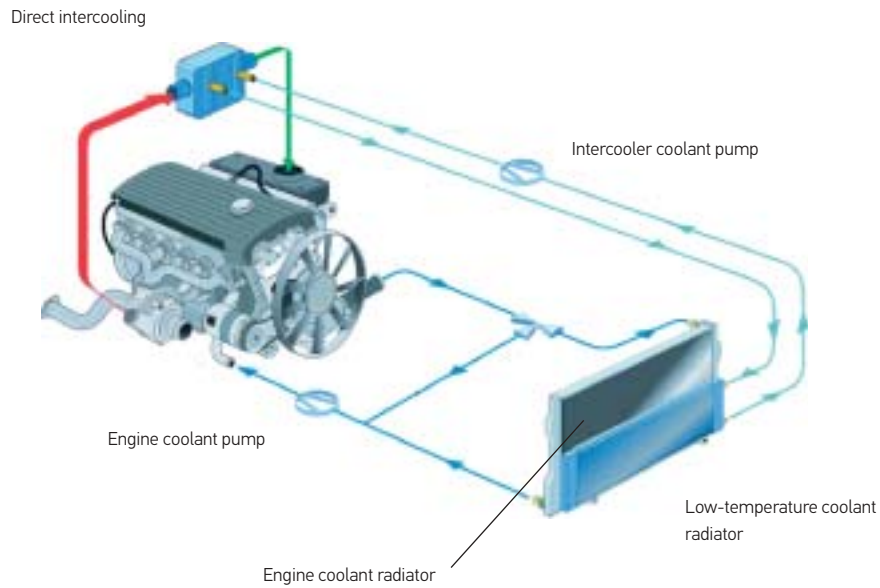

Effects of failure

A defective intercooler can manifest itself as follows:

- Lack of engine power
- Loss of coolant (with coolant-cooled intercooler)
- Increased emissions
- Increased fuel consumption

These are possible causes:

- Damaged or blocked hose/coolant connections
- Loss of coolant or secondary air due to leaks
- Exterior damage (caused by gravel throw, accident)
- Reduced air flow rate (dirt)
- Lack of heat exchange due to inner soiling (corrosion, sealing agent, limescale deposits)
- Failure of the coolant pump (in the case of low-temperature coolant radiators)

Troubleshooting

Test steps towards recognizing faults:

- Check coolant level
- Check coolant for soiling/discoloring and antifreeze content
- Watch out for external damage and soiling
- Check system components and connecting elements (hose connections) for leaks
- Check coolant pump
- Check fans and auxiliary fans
- Check the flow rate (blockage due to foreign materials, corrosion)

OIL COOLER

General

The cooling of oils under a high thermal load (engine, transmission, power steering) by oil coolers or the guarantee of an almost constant temperature results in significant advantages. The intervals between oil changes can be extended and the service life of various components increases. Depending on the requirements, oil coolers are located in/on the engine radiator or directly on the engine block. A basic distinction is made between air-cooled and coolant-cooled types of oil cooler.

Design/Function

These days, conventional cooling is no longer sufficient for vehicle units which are under a high load. Thus, for example, the engine oil is cooled extremely irregularly, since it is dependent on outside temperature and the airstream.

Air-cooled oil coolers which are located in the air flow at the vehicle front end, contribute to sufficient cooling of the oil temperature. Liquid-cooled oil coolers are connected to the engine coolant circuit and provide optimum temperature regulation. In this case, coolant flows through the oil cooler. When the engine is hot, the coolant withdraws the heat from the oil, thus cooling it down. When the engine is cold, the coolant warms up more quickly than the oil and thus dissipates heat to the oil.

This helps the oil to reach its operating temperature more quickly. Quick achievement of the operating temperature or the maintenance of a constant operating temperature is particularly important in the case of automatic transmission and power steering. Otherwise, steering could become too stiff or too easy-running, for example.

Today, tube coolers are being replaced more and more by compact all-aluminum stack-disc coolers. They offer a larger cooling surface combined with low package space and an extremely wide range of mounting locations in the engine compartment.



Effects of failure

A defective oil air cooler can manifest itself as follows:

- Poor cooling performance
- Loss of oil
- Increased oil temperature
- Contaminated coolant

These are possible causes:

- Poor heat exchange caused by external or internal soiling (insects, dirt, oil sludge, corrosion)
- Loss of oil as a result of damage (accident)
- Oil entering the cooling system (interior leak)
- Oil loss through leaky connections

Troubleshooting

Test steps towards recognizing faults:

- Check oil and coolant levels
- Check oil cooler with regard to exterior soiling, damage (hairline cracks)
- Check coolant for soiling/discoloring and antifreeze content
- Watch out for external leaks (connections)
- Check the flow rate (blockage due to foreign materials, corrosion, oil sludge, etc.)



VISCO® CLUTCH

General

The Visco® fan drive is part of the Visco® fan. It has the task of creating the frictional connection between the drive and fan wheel depending on the temperature, and influencing its speed. There is a plastic fan attached to the coupling which generates the air flow as required. Visco® fans are mainly used in cars with longitudinally mounted large-capacity engines and in trucks.

Design/Function

The Visco® fan drive is usually driven directly by the engine via a shaft (Fig. 1). If no cooling air is required, the Visco® fan drive shuts down and rotates at low speed. As requirements increase, silicone oil flows from the reservoir into the working chamber. The drive torque is transferred from there to the fan, the continuously variable speed of which is set automatically on the basis of the operating conditions by means of wear-free fluid friction.

The switching point is around 80°C. In the case of conventional Visco® fan drives, the air expelled by the fan strikes a bi-metal (Fig. 2) which thermally deforms and has the effect of opening and closing a valve via a pin and valve lever. The transferable torques and fan speeds are set depending on the valve position and thus the amount of oil in the working chamber. The amount of oil required is 30 - 50 ml (passenger car).

Even with the working area completely full there is a difference between the speed of the drive and the speed of the fan (slip). The heat produced is dissipated to the ambient air via the cooling fins. The electrically actuated Visco® fan drive is controlled directly via sensors. A regulator processes the values and a pulsed control current carries these to the integrated electromagnet. The defined guided magnetic field regulates the valve which controls the internal oil flow via an armature. An additional sensor for fan speed completes the closed-loop control circuit.



Fig. 1



Fig. 2

Effects of failure

The following are signs that the Visco® fan drive is faulty:

- Increased engine temperature or coolant temperature
- Loud noise
- Fan wheel continues to run at full speed under all operating conditions

These are possible causes:

- Lack of frictional connection through leaking oil
- Loss of oil due to leak
- Soiling of the cooling area or bi-metal
- Internal damage (e.g. control valve)
- Bearing damage
- Damaged fan wheel
- Permanent full frictional connection due to faulty fan drive

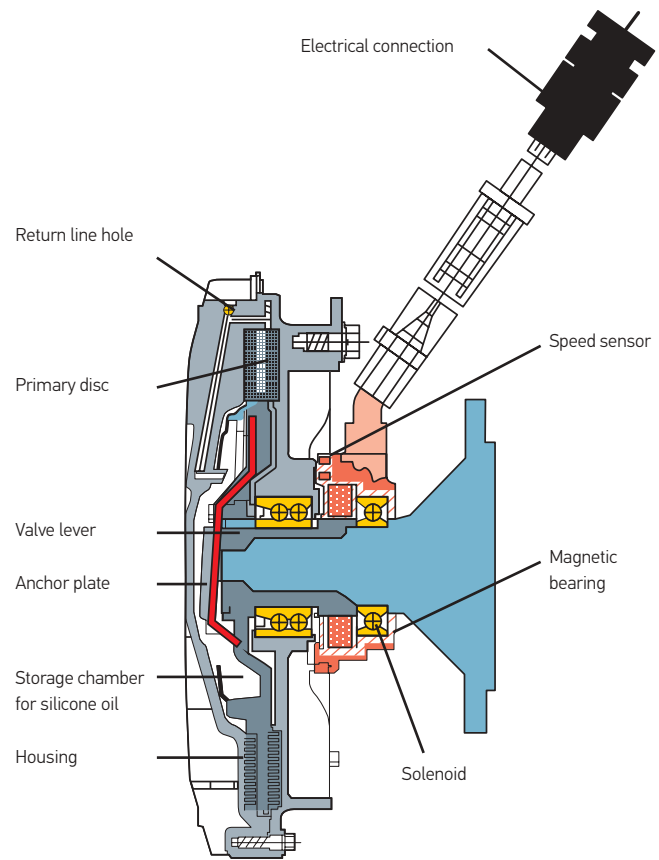

Electronically-controlled Visco® fan drive

Troubleshooting

Test steps towards recognizing faults:

- Check the coolant level and the antifreeze content
- Check the Visco® fan with regard to outer soiling and damage
- Check the bearing for play and noises
- Make sure no oil is leaking
- Check the Visco® fan drive by turning it by hand with the engine switched off. With the engine cold, the fan wheel should be easy to turn and with the engine hot it should be hard to turn.
- If possible, check the slip of the fan drive by comparing the speed of the fan with the speed of the drive shaft. With full frictional connection, the difference may only be max. 5% for directly driven fans. An optical revolution counter with reflective strips is suitable for this purpose (Fig. 3)
- Check the electrical connection (electronically-triggered Visco® fan drive)
- Check air cover/air baffles
- Make sure the air flow rate of the radiator is sufficient

VISCO® FANS

General

Dissipating the heat in more powerful engines requires not only high-capacity radiators, but also fans and fan drives that can supply cooling air particularly efficiently. Visco® fans comprise a fan wheel and a Visco® fan drive. They are used in the case of longitudinally-mounted engines. They are fitted in front of the radiator (direction of travel) and are driven by a V-belt or directly by the engine.



Design/Function

The fan wheel is usually made of plastic and is screwed to the Visco® fan drive. The number and position of the fan blades vary according to design. The housing of the Visco® fan drive is made of aluminum and has numerous cooling fins. The Visco® fan can be controlled by a self-regulating bi-metal fan drive depending purely on the temperature. The parameter here is the ambient

temperature of the coolant radiator. The electrically controlled Visco® fan drive is another variant. This is controlled electronically and is operated electromagnetically. Here, the input quantities of different sensors are used for control. Further information can be found in the technical information for Visco® fan drives.

Effects of failure

The following are signs that the Visco® fan is defective:

- Loud noise
- Increased engine or coolant temperature

These are possible causes:

- Damaged fan wheel
- Oil loss/leaks
- Soiling of the cooling area or bi-metal
- Bearing damage

Troubleshooting

Test steps towards recognizing faults:

- Check coolant level
- Check the fan wheel for damage
- Make sure no oil is leaking
- Check the bearing for play and noises
- Check the fastening of the fan wheel and the Visco® fan drive
- Check that the air baffles/air cover are installed and securely fitted.



COOLANT, ANTIFREEZE AND CORROSION PROTECTION

Coolant is the generic term for the cooling liquid in the cooling system.

Coolant protects against frost, corrosion, overheating and lubricates. Its task is to absorb the engine heat and dissipate it via the cooler. The coolant is a mixture of tap-water and antifreeze (glycol/ethanol) mixed with various additives (bittering agent, silicate, antioxidant agents, foam inhibitors) and colored. Bittering agents are used to prevent the coolant from being drunk inadvertently. Silicates form a protective layer on the metal surfaces and prevent limescale deposits, etc. Antioxidants prevent component corrosion. Foam inhibitors suppress the foaming of the coolant. Glycol keeps hoses and seals supple and increases the boiling point of the coolant.

The mixing ratio of water and antifreeze should be from 60:40 to 50:50. This usually corresponds to antifreeze protection from -25°C to -40°C. The minimum mixing ratio should be 70:30 and the maximum mixing ratio 40:60. Further increasing the proportion of antifreeze (e.g. 30:70) does not lower the freezing point any further. On the contrary, undiluted antifreeze freezes already at around -13°C and at temperatures of above 0°C does not dissipate sufficient engine heat. The engine would overheat. As the boiling point of glycol is very high, the boiling point of the coolant can be raised to up to 135°C by using the right mixing ratio. Therefore, a sufficient antifreeze share is important even in warm countries.

Always follow the manufacturer's instructions. A typical composition could be 40%/60% or 50%/50% when using inhibited water (drinking water quality).



The coolant and its additives are subject to a certain wear, i.e. part of the additives will be used up in the course of some years. Once the corrosion protection additives have been used up, brown discoloration of the coolant will be evident. This is why manufacturers such as John Deere, Massey Ferguson and Valtra prescribe a change interval of 2000 hours or 2 years, for example. With John Deere for example, the replacement interval can be extended to 6 years or 6000 hours using a special coolant (Cool-Gard II and Premix). As a rule, the coolant should be changed if it has become contaminated (oil, corrosion) and in vehicles which are not filled with long-life coolant.

The vehicle manufacturer's instructions must be followed in terms of the specifications, replacement interval, mixing ratio and the miscibility of the antifreeze.

Coolant must not get into the groundwater or be discharged via the oil trap. Coolant must be collected and disposed of separately.

RADIATOR MAINTENANCE

The radiator requires no maintenance as protection inside and outside is already provided during production (special to Behr). As is the case with condensers, cleaning by jet cleaner with low pressure (from inside to outside) is possible.

Reduced compressed air can also be used for cleaning from the outside.

FLUSHING THE COOLING SYSTEM

If the cooling system is contaminated, then the coolant must first be drained and the cooling system must be flushed.

Contamination may be:

- Oil (defective cylinder head gasket)
- Rust (internal corrosion of engine)
- Aluminum (internal corrosion of radiator)
- Foreign substances (additives/sealant)
- Foreign particles (defective coolant pump)

Depending on the contamination level, the cooling system is cleaned with hot water or with a special flushing liquid.

Depending on vehicle manufacturer and symptom, there are various approaches to flushing.

The degree of contamination and the vehicle manufacturer's instructions therefore determine the method and the flushing agent to be used. It should at any rate be observed that, due to the design (e.g. flat tube) of modern cooling systems, not all components can be flushed and therefore need to be replaced.

This applies in particular for the following components:

- Thermostat
- Radiator
- Electrical valves
- Caps
- Heat exchanger

If the coolant level in the expansion tank cannot be checked due to contamination (oil, rust), then the tank must also be replaced. The thermostat and cap should be replaced as a rule.

If special cooling system cleaners are used, then care must be taken that they do not attack sealing materials and do not get into the groundwater or are removed via the oil trap. The cleaning agents must be collected together with the coolant and be disposed of separately.

After flushing, the system must be filled with coolant in accordance with the vehicle manufacturer's instructions (specification, mixing ratio), bled and checked for function and leak tightness.

BLEEDING THE SYSTEM WHEN FILLING IT

Air in the cooling systems of vehicles has become a widespread problem. The air bubbles are caused by positioning of the radiator or expansion tank at the level of the engine or even below it. Thus, the complete bleeding of the cooling system after repair or exchange of the coolant may be a serious problem. Air in the cooling system considerably reduces the circulation of the coolant and may lead to engine overheating and the consequent severe damage. The radiator vacuum filling unit provides assistance in this regard.

The system can be used to:

- Eliminate air bubbles
- Check for leaks
- Quickly refill the cooling system

Airlift is connected to the radiator or the expansion tank using the adapter provided. A compressed air hose, which is normally used to operate pneumatic tools, is then connected. Via a special valve, the cooling system is then evacuated and a powerful vacuum generated. The enclosed suction hose is connected and the cooling system filled with fresh water/antifreeze mixture from a clean coolant tank (bucket, can). With the help of the manometer which measures the vacuum, the leak tightness of the entire system can be checked at the same time.

Checking the Cooling System via a Pressure and Pressure Drop Test

To check the cooling system for leaks, the use of a pressure tester is recommended. The cooling system is pressurized with the aid of a hand pump. By observing the manometer, any detected pressure drop may be an indication that there is a leak in the cooling system. With the help of universal or vehicle-specific adapters, the pump can be connected via a quick coupling to almost all common trucks, and passenger agricultural and construction vehicles.

If the leaks are hard to find, the cooling system can be filled with contrast agent beforehand.



TYPICAL DAMAGE

The photos show typical damage due to various causes.

Radiator

All faults impair the performance of the radiator. Repairs are not normally carried out on modern coolant radiators, because aluminum is difficult to weld and the small ducts might become blocked as a result of welding. Sealant must not be used, because it can cause blockages and reduce performance.



Deposits due to a discharge of oil are caused by engine oil entering the coolant circuit as a result of a damaged cylinder head gasket.



Limescale deposits due to the use of pure water (without coolant).

Heat exchanger

Limescale deposits and the use of sealants may clog the heat exchanger in the same way as the radiator. Such deposits can be removed by flushing with certain cleaning agents. Note the vehicle manufacturer's instructions.



COOLING SYSTEM CHECK AND DIAGNOSIS

In the case of malfunction in the cooling system (e.g. insufficient heating output, engine doesn't reach operating temperature or overheats) the cause of the problem can be found using simple methods. Firstly, the cooling system should be checked for sufficient coolant, contamination, antifreeze and leaks. There should also be sufficient tension in the V-belt or V-ribbed belt.

After that, troubleshooting may be continued, depending on the symptom, by observing components or checking temperatures as follows:



Engine is overheating:

- **Is the temperature indicated realistic?**
(check cooling water temperature sensor and indicating instrument if necessary)
- **Are the radiator or upstream components (condenser) free of contamination in order to guarantee an unrestricted air flow rate?**
(clean components if necessary)
- **Does the radiator fan or auxiliary fan work?**
(check switch-on point, fuse, thermal switch, fan control unit, check for mechanical damage)
- **Does the thermostat open?**
(measure temperature before and after the thermostat; remove thermostat and test it in a water bath if necessary)
- **Is the radiator clogged?**
(check temperature at radiator inlet and outlet, check rate of flow)
- **Does the coolant pump work?**
(check tight fit of pump wheel on the drive shaft (no slip))
- **Does the pressure/suction relief valve of the radiator cap or expansion tank work?**
(use test pump if necessary, check whether the seal of the cap is damaged or missing)

Engine does not get warm:

- **Is the temperature indicated realistic?**
(check cooling water temperature sensor and indicating instrument if necessary)
- **Is the thermostat constantly open?**
(measure temperature before and after the thermostat, remove thermostat and check in water bath if necessary)
- **Does the radiator fan or auxiliary fan work permanently?**
(check switch-on point, thermal switch, fan control unit)



Heating not sufficiently hot:

- **Does the engine reach operating temperature or does the cooling water get warm?**
(if applicable, first check items at "Engine does not get warm")
- **Does the heating valve open?**
(check electric control or bowden cable and valve)
- **Is the heating radiator (heat exchanger) clogged?**
(check temperature at heat exchanger inlet and outlet, check rate of flow)
- **Does the flap control system work?**
(check flap positions and limit stops, fresh air/recirculated air function, air outlet nozzles)
- **Does the interior blower work?**
(noise, fan speeds)
- **Is the cabin filter soiled and is the air flow rate sufficient?**
(check cabin filter, check ventilation ducts with regard to secondary air)



Flushing the Cooling System

If the cooling system is contaminated, the coolant must be drained off and the cooling system flushed.

Contamination may be:

- Oil (defective cylinder head gasket)
- Rust (internal corrosion of engine)
- Aluminum (internal corrosion of radiator)
- Foreign substances (additives/sealant)
- Foreign particles (defective coolant pump)

Examinations of failed radiators have shown that rust sludge is the most frequent cause of soiling.

These are the result of no or insufficient cleaning during repairs to the cooling system, or filling the system with the wrong types of antifreeze or using the drained coolant again. Rust sludge can become deposited and block narrow channels, and accelerates corrosion if bright metal surfaces are covered with it (anodic effect with pitting corrosion) and acts as an abrasive in the coolant circuit, particularly in locations where the direction of flow is diverted.

Cleaning

Depending on the contamination level, the cooling system is cleaned with hot water or with a special flushing liquid.

Depending on vehicle manufacturer and symptom, there are various approaches to flushing. As a rule, the cooling system must be flushed and the thermostat and vent cap replaced when changing the coolant.

The procedure at John Deere is as follows, for example:

- Allow the coolant to cool down
- Put ignition switch in the "Run" position
- Turn the temperature switch to "Warm"
- Drain the cooling system via drain valves
- Remove thermostat
- Fill cooling system with special cleaning solution according to the manufacturer's specifications

- Run the engine for 15 minutes and then drain the cooling system once it has cooled down
- Fill the cooling system with fresh water, run the engine for 15 minutes then drain cooling system again once it has cooled down.
- Replace the thermostat and cap
- Refill the cooling system with antifreeze/water mixture according to the manufacturer's specifications
- Bleed the system, check for leaks and check the cooling water level

The ignition must be switched on and the highest setting of the temperature controller selected during the entire drainage, flushing and refilling process. This guarantees that the system will be drained completely. Check the cooling water level again after several operating hours



Most cleaning agents are based on compounds containing formic acid, oxalic acid or hydrochloric acid which must never remain in the cooling system. **Always flush out thoroughly!** Sometimes leaks that were not visible before can come to light after cleaning. This is often reputed to be caused by aggressive cleaning agents. In actual fact the leak was already there, and leak tightness was only ensured by the dirt blocking the hole. Behr Hella Service recommends cleaning the cooling circuit before any new components are installed.

The degree of contamination and the vehicle manufacturer's instructions specify the method and the flushing agent to be used.

It should be observed that, due to the design (e.g. flat tube) of modern cooling systems, not all components can be flushed and therefore need to be replaced.

This applies in particular for the following components:

- Thermostat
- Radiator
- Electrical valves
- Caps
- Heat exchanger

If the coolant level in the expansion tank cannot be checked due to the contamination (oil, rust), then the tank must also be replaced.

The thermostat and cap should be replaced as a rule.

When cooling system cleaners are used, care must be taken that they do not corrode any sealing materials and do not get into the groundwater and are not removed via the oil trap. The cleaning agents must be collected together with the coolant and be disposed of separately. After flushing, the system must be filled with coolant according to the vehicle manufacturer's instructions (observe specification, mixing ratio), bled and checked for function and leak tightness.

Antifreeze = rust inhibitor!





Sales and other information available at:

HELLA KGaA Hueck & Co.

Rixbecker Straße 75

59552 Lippstadt, Germany

Tel.: +49 2941 38-0

Fax: +49 2941 38-7133

Internet: www.hella.com

© BEHR HELLA SERVICE GmbH, Schwäbisch Hall

922 999 136-295 J00886/KB/02.15/0.15

Printed in Germany

Subject to technical and price modifications