

Technical Information

Electronics – Actuators: Body Control Devices



*Ideas today for
the cars of tomorrow*

Two complementary demands, one for more convenience of operation and safety, the other for the desire to reduce costs inside the vehicle led to the development of reliable and innovative actuators. They are required for locking systems, locking devices and other applications in the interior and seat areas.

Hella has been designing and manufacturing actuators for over 40 years. During that time, actuators had to meet ever-advancing requirements. While functionalities are becoming increasingly complex, their operability is to be warranted for an extending life expectancy.

To meet these requirements, Hella relies on tool-kit systems and standard components which allow us to provide solutions for a wide range of practical applications at optimized costs and with excellence of production in mind. These resources help us to reduce the new-unit development time, including units that are tailored to specific customer needs.

Actuators made by Hella combine two key benefits: they are powerful constructions perfectly adapted to their particular functions and still their design remains simple. Ongoing process improvement guarantees a consistent level of quality.

Hella runs facilities for actuator development and production everywhere in the world and is currently in the process of establishing further international locations, particularly in the NAFTA and Asian regions.



Different designs of Hella standard car-body actuators

Standard car-body actuators

Typical applications of standard car-body actuators include the locking or unlocking and remote control of fuel filler-caps, tailgates, hoods, glove and other compartments as well as various special applications, e.g. in passenger seats. Hella provides a wide range of customized and system-specific tool-kit solutions which are all mainly distinguished by their small footprint, ease of installation and a good price/performance ratio.

Actuators used in passenger-seat applications, for example, help to replace manually operated mechanical solutions, leaving more space for airbags or improving the convenience of operation. Folding headrests improve the rear view, thus enhancing the safety of pedestrians.



Latest generation standard car-body actuator with a filler-cap application

Since 1996, Hella has been deploying fully automatic and semi-automatic production facilities on 3 continents to produce more than 45 million actuators. Our current annual production capacity of is more than 9 million pieces.

The properties of standard car-body actuators are tailored to customer-specific functional needs such as:

- Actuating forces and speeds
- Electromotor-controlled return or automatic spring return (without current)
- Attachment: detached from the structure to eliminate structure-borne noise as required
- Mechanical elements to connect the actuator with the application
- Electrical connection (plug and cable) – standardized or customized as necessary
- Dry-room or wet-room design, as the application requires

Technical Data

Body actuators consist of an electromotor drive installed in a plastic housing. Laser welding is the striking feature of the assembly. Variants with 12 VDC or 24 VDC motors are available. Thermal overload protection integrated in the motor upon request. Some of the plastic gears can be equipped with return control springs.

Standard actuators	
Nominal voltage	12 V/24 V
Temperature range	-40 °C to +80 °C
Stroke	up to 18 mm
Force	up to 50 N
Protection	IP5K0/IP5K4
Life (cycles)	up to 100,000

Micro actuator

Whereas Hella developed its “micro actuator” primarily with fuel-tank modules in mind, it can also be used for service flaps. Its functions range from locking and unlocking to remote control and soft-touch. This standardized product is delivered with a comprehensive description of the mechanical and electrical interface.

The “micro actuator” integrates directly into the fuel tank modules. It can either be pre-assembled by the tier 1 supplier or installed afterward by the OEM.



“Micro actuator” for integration into fuel-tank modules

Key features of “micro actuators:”

- Very small dimensions
- Electromotor-controlled return or automatic spring return (without current)
- Easy snap-on installation
- Integration into the fuel-tank module makes it independent of car-body tolerances
- Water-protection
- Explosion protection certificate
- Commonly used electrical standard connector
- Interface for emergency actuation

The soft-touch variant of the “micro actuator” is one of Hella’s innovations. Pressing down on the filler cap causes the actuator to send a signal to the control unit. The unit controlling the central locking system, for example, can respond by granting or denying access to the fuel-tank module, depending on customer-specific software algorithms. The “micro actuator” helps to considerably save on the overall layout of the on-board system and also to reduce the OEM’s costs of installation and logistics.

Technical Data

Micro actuator	
Nominal voltage	12 V
Temperature range	–40 °C to +80 °C
Protection	IP5K4
Life (cycles)	up to 60,000

High force actuator

Hella is currently developing a new product, the “high force actuator,” designed for locking devices and seat-area applications, which exhibits great actuating forces. It is part of a new tool-kit system at actuator level where it combines with a set of customized accessories to respond to various requirements.

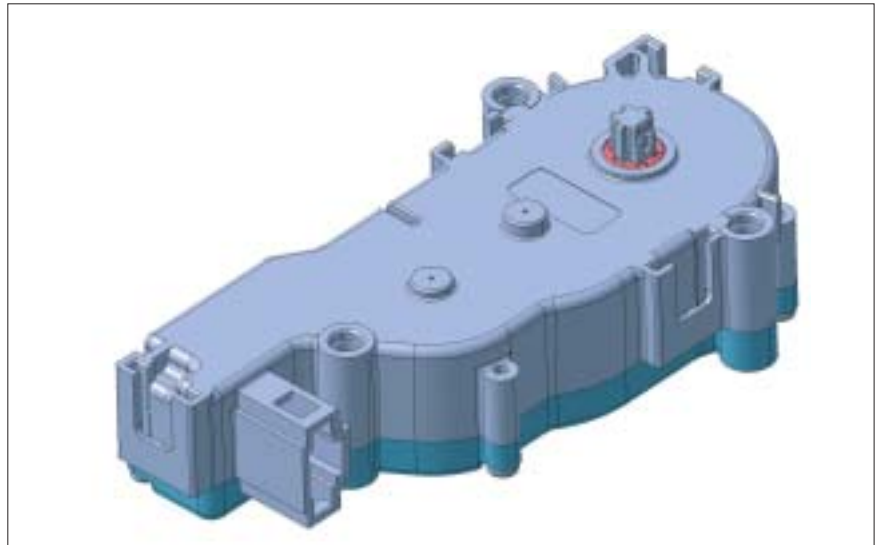

Basic “high force actuator” unit

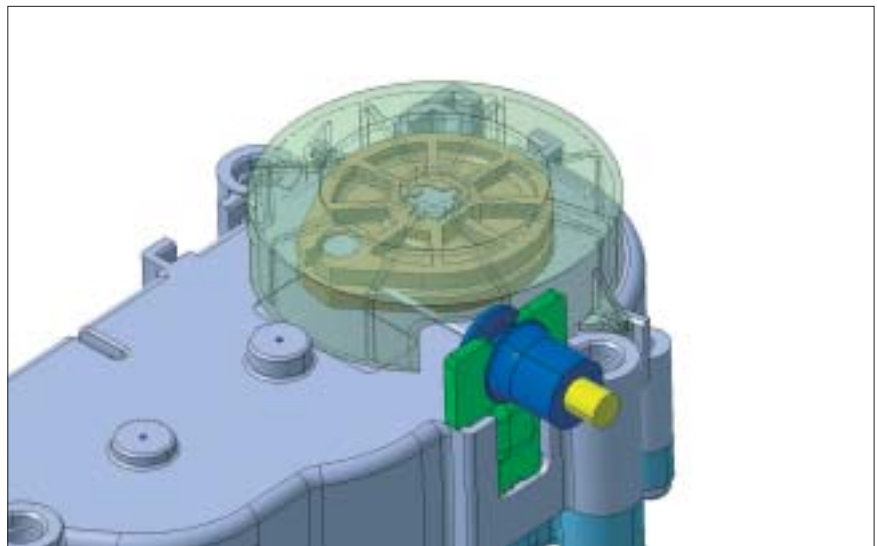

“High force actuator” with accessories such as pulley and protective cap

Key features of “high force actuators”:

- Great actuating forces
- Electromotor-controlled return
- Standardized electrical connection via Euro or US plug
- Dry-room applications
- Stops for limiting the angle of rotation up to 335° or without limitation
- Drive pinion of housing/cover or dual pinion
- Various interfaces for bowden cable connection (making it unnecessary for the actuator to directly connect with the car body)
- Customized driven elements such as pulleys, levers, ...
- Optional caps for protecting the driving mechanism
- Class 3 RFI suppression

Technical Data

High Force Actuator	
Nominal voltage	12 V/24 V
Temperature range	-40 °C to +85 °C
Nominal torque	300 Ncm @ 12 U/min
Protection	IP5K0
Life (cycles)	up to 50,000

Hella KGaA Hueck & Co.
Rixbecker Straße 75
59552 Lippstadt, Germany

Phone: +49 (0) 29 41 38-0
Fax: +49 (0) 29 41 38-71 33
E-mail: info.oe@hella.com
Internet: www.hella.com

Technical enquiries:
PLE-8 Actuators
Phone: +49 (0) 29 41 38-29 37
Fax: +49 (0) 29 41 38-83 57



*Ideas today for
the cars of tomorrow*