

# Mining News Issue 4

## Hella Australia

**LED Switches**



**Voltage Tester**



**Loom Tape**



**DuraLed® ECE**

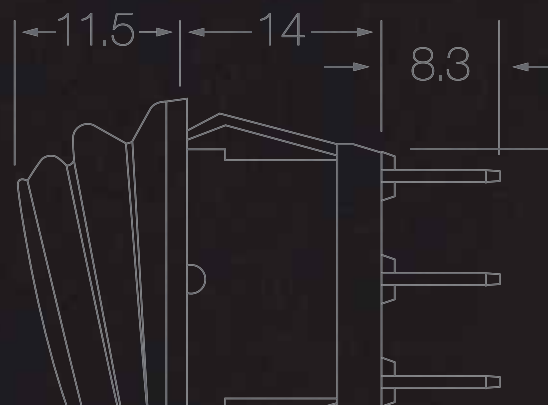
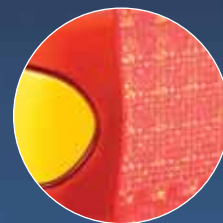

## Compact LED Rocker Switches



### Description

Compact, heavy-duty LED illuminated Rocker Switches featuring durable nylon frame and waterproof rubber sealing boot for additional protection in industrial and mining environments. Fitted with push-on terminals, removing the need for regular globe replacement. Weatherproof from front if installed correctly.

### Mounting

Mounting opening 20mm dia.

### Panels

Suitable for panels up to 2.5mm thick.

### Protection

Weatherproof (from front)

### Voltage

12 or 24V DC LED included (non-replaceable).

### Maximum Load

10A at 12V DC  
5A at 24V DC

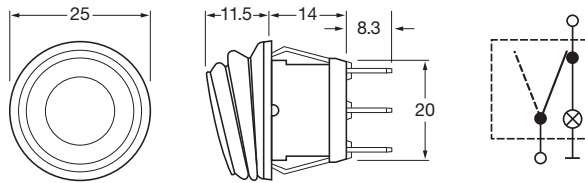

Description	Part No.
<b>LED Rocker Switches 24VDC</b>	
Amber Illuminated	<b>HM4400A</b>
Red Illuminated	<b>HM4400R</b>
Blue Illuminated	<b>HM4400B</b>
Green Illuminated	<b>HM4400G</b>
<b>LED Rocker Switches 12VDC</b>	
Amber Illuminated	<b>HM4400A-12V</b>
Red Illuminated	<b>HM4400R-12V</b>
Blue Illuminated	<b>HM4400B-12V</b>
Green Illuminated	<b>HM4400G-12V</b>



Amber



Red



Blue



Green

**Description**

Universal voltage tester featuring 2 probes and dual indicator diodes for general purpose electrical testing. Designed to test for presence of AC voltage in live circuits and +/- polarity of DC voltages. Compact design and ultra fast response time for quick and easy testing.

**Voltage Range**

6-30V DC  
125 - 380V AC/DC

**Current Inputs**

1 - 1.5mA

**Response Time**

3 ms

**Note**

*The instrument does not indicate whether shock-hazard voltage is present.*



**Universal Voltage Tester**

Description

Part No.

Universal Voltage Tester

**HM7015**



**Description**

Polyethylene self-amalgamating loom tape ideal for waterproof sealing of electrical connections, temporary repair and sealing of plumbing joints. Also suitable for emergency repair of radiators, engine hoses and auto electrics. Easy to unwind and resistant to water, ozone, UV and a wide range of chemicals including alkalis, hydraulic fluids and vegetable oils.

**Tape Thickness**

0.5mm, tensile strength at break 12 N/cm

**Breakdown Voltage**

34 kV/mm

**Elongation**

600%

**Service Temperature**

-35°C to +130°C

**Self-Amalgamating Loom Tape**



Description

Part No.

Self-Amalgamating Tape

**HMAT85**

## DuraLed® ECE Approved Signal Lamps



Hella's range of DuraLed® lamps has been extended to include new ECE approved signal lamp versions. They suit a variety of vehicle applications and are designed for ease of fitment and service durability. The lamps incorporate the latest in LED technology for low maintenance requirements, low current draw and ultra long service life.

DuraLed® lamps feature unique designs with shallow shapes and concealed mounting screws for enhanced protection against damage.

All lamps are pre-wired with multi-core sheathed cable, fully sealed against dust and moisture to International Protection Standards IP6K6 and IP6K7, and are ECE approved.

The material used is a new generation of acrylics with high tolerance to chemicals and washing fluids as well as enhanced impact resistance, making them ideal for vehicles frequently washed with standard automotive chemicals. The optic appears clear until illuminated in the designated signal colour.

DuraLed® ECE approved signal lamps feature low power consumption and Multivolt™ circuitry, ensuring full light output at any input voltage between 9 and 33 volts. The lamps may be mounted vertically or horizontally.

### Product Features

- Easy Installation
- Variety of surface mount options
- Ultra wide angle optics for enhanced side visibility
- Ultra low power consumption
- Multivolt™ 9-33V DC
- ECE Approval
- Fully sealed against dust and moisture

### Specifications

Voltage	Multivolt™ 9-33V DC		
Power Consumption	Rear Direction Indicator	9W	
	Rear Position Lamp	2W	
	Park Lamp	2W	
	Stop Lamp	9W	
Protection	Reverse Polarity Protection 5.0kW Transient Voltage Suppressor (TVS)		
Protection Codes	IP6K6 (protection against dust and high pressure water jets) IP6K7 (protection against temporary water immersion)		
Approvals	HM060621 (Red)	E13 020533	e4 020889
	HM070621 (Amber)	E13 010363	e4 020904

Description	Part No.
<b>DuraLed® ECE Signal Lamps</b>	
Stop/Tail Signal (Red Illuminated)	<b>HM060621</b>
Rear Turn Signal (Amber Illuminated)	<b>HM070621</b>



HM070621  
(Amber Illuminated)

HM060621  
(Red Illuminated)

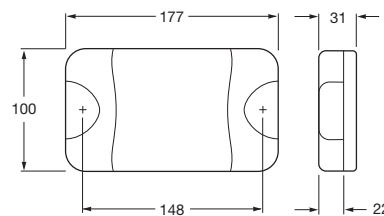

Hella Mining Centre of Excellence  
Hella Australia Pty Ltd  
ABN 77 006 256 524  
54-76 Southern Road,  
Mentone, Victoria 3194  
P.O. Box 89  
Mentone, Victoria 3194

Tel: (03) 9581 9333  
Fax: (03) 9585 2654  
E-mail: [mining@ha.hella.com](mailto:mining@ha.hella.com)  
Web: [www.hella.com/mining](http://www.hella.com/mining)

Special note: The illustrations, information and specifications presented and referred to in this leaflet were correct at the date of printing. However, Hella reserves the right, subject to all applicable laws, at any time, at its discretion and without notice, to discontinue or change the specifications or the design of any product referred to herein. The data and suggested applications are given as a general guide only and users should independently evaluate the suitability of each product for any particular application.

**Hella Customer Service 1800 061 729**