



BRIEF INFORMATION

Level sensors

- Level sensors of the fourth generation: revamped design and function
- Particularly high robustness against interference
- Continuous measurement of the engine oil level in the static and dynamic range

PRODUCT FEATURES

Application

Oil sensors in vehicles ensure that the engine does not run with insufficient or too little oil without such a situation being noticed. The tried-and-tested technology of ultrasonic sensors works on the run-time principle and records the fill level continuously when the vehicle stands or is being driven. When the engine is running (dynamic measuring range), the fill level is significantly lower than the fill level when the engine is at a standstill (static operation). An oil dipstick measures the oil level in engines only in the static operation. The HELLA oil level sensors record the oil level continuously, i.e. both in the dynamic and static operation. Meaning information is provided about the oil level during the entire engine operation, a process which can often last several hours in construction vehicles, tractors and forklifts.

The sensor continuously monitors the oil level during the entire operation of the engine. This function ensures that the oil level does not fall below the required minimum during engine operation (which would result in engine damage). It also prevents overfilling of the engine in engine operation. Another advantage of the sensor is the integrated temperature sensor, which provides an input variable for the thermal management of the engine.

Marginal influences such as vehicle leaning, lateral and longitudinal accelerations are compensated by averaging out in the vehicle's control unit.

The use of the oil level sensor for the measurement of special media, e.g. transmission and hydraulic oils require prior testing and approval by HELLA.

LEVEL SENSORS TO RECORD THE LIQUID LEVEL (STATIC AND DYNAMIC)

Design and function

The sensor architecture of the PULS (Packed Ultrasonic Level Sensor) oil level sensor consists of one single multi-chip module that integrates the ultrasonic sensor, the temperature sensor and also an ASIC (Application Specific Integrated Circuit). This compactness gives the sensors a higher level of impact and vibration resistance than those sensors fitted with a large number of electronic components. The ultrasonic sensor integrated in the multi-chip module transmits a signal that is reflected by the oil/air interface of the engine oil. The term of the signal is measured and the liquid level is calculated using the speed of sound in the medium. The damping cup installed above the multi-chip module is designed "to calm" the medium, (especially) in the dynamic measuring range. The damping cup has openings at the base and at the tip, which allow the oil to flow permanently.

Flush mounting

The sensor is designed to be vertically flush-mounted from below into the bottom of the oil pan. Usually the oil level sensor is located on a ledge in the oil pan in order to protect the sensor base. This installation position, combined with the openings which make a permanent flow of oil possible, prevents sludge from forming within the damping cup.

Schematic diagram

Optimal sensor position in the oil pan for dynamic measurement: a central positioning in the oil pan

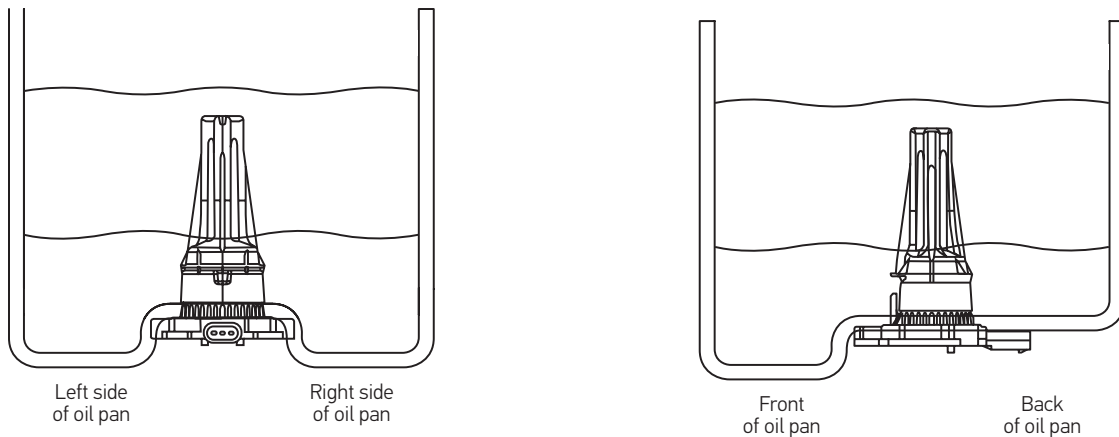

Dynamic measurement of engine oil

For dynamic measurement (while the engine is running), an evaluation algorithm in the control unit must be developed, which compensates for the marginal influences of the engine (oil volume, oil temperature, speed) and of the vehicle (longitudinal and lateral acceleration, uphill and downhill motion). As a result of subsequent averaging, the influences brought about by driving conditions cancel themselves out over longer periods of time. Hence, either a warning can be triggered with respect to the minimum oil volume reached or the oil volume that is actually still available can be calculated.

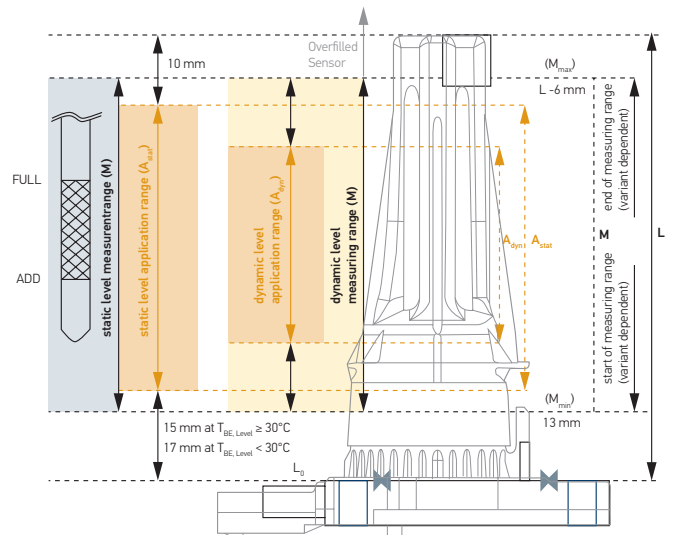
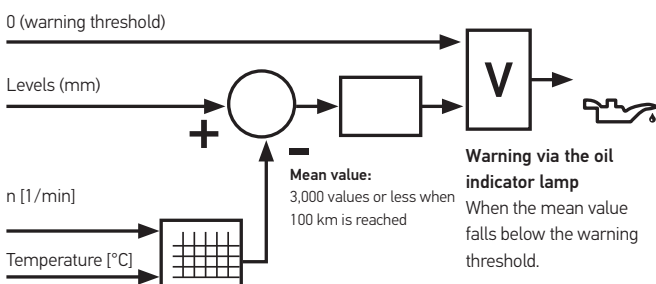

3D characteristic diagram: compensation of engine speed and oil temperature

T₁: Temperature evaluation (T₁ Temp)

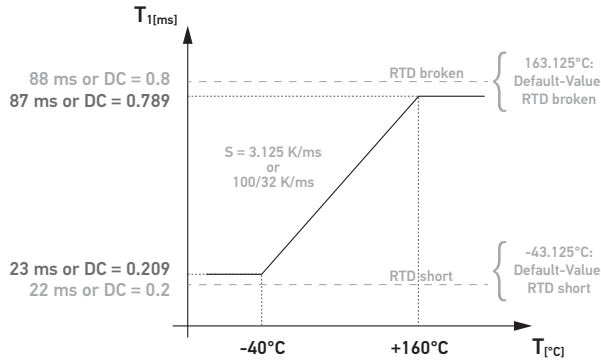

$T_1/T = DC = 0.2 : T_1 = 22 \text{ ms} \Rightarrow$ Short circuit temperature sensor (-43 to 125°C)
 $T_1/T = DC = 0.209 : T_1 = 23 \text{ ms} \Rightarrow$ -40°C
 $T_1/T = DC = 0.789 : T_1 = 87 \text{ ms} \Rightarrow$ 160°C
 $T_1/T = DC = 0.8 : T_1 = 88 \text{ ms} \Rightarrow$ Temperature sensor defective (163 to 125°C)

T₂: Temperature evaluation (T₂ Level)

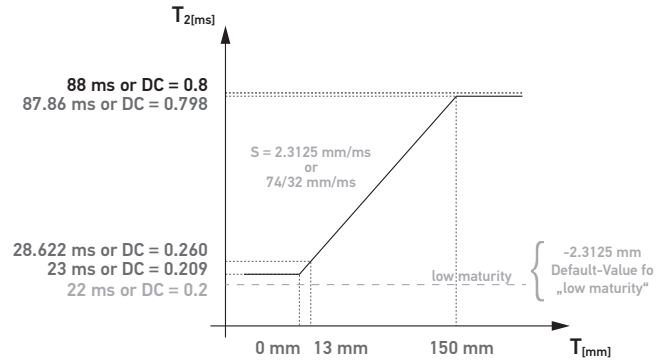

$T_2/T = DC = 0.2 : T_2 = 22 \text{ ms} \Rightarrow$ Unreliable signal (Level output -2.3125 mm)
 $T_2/T = DC = 0.209 : T_2 = 23 \text{ ms} \Rightarrow$ Level = 0 mm
 $T_2/T = DC = 0.260 : T_2 = 28.622 \text{ ms} \Rightarrow$ Level = 13 mm
 $T_2/T = DC = 0.798 : T_2 = 87.86 \text{ ms} \Rightarrow$ Level = 150 mm
 For levels below 13 mm or above 150 mm, T₂ is fixed at 28.622 ms or alternatively at 87.86 ms.

T₃: Diagnostic evaluation

PWM Pulse (Diagnostic values marked in bold print)			Diagnostic Information	Diagnostics of environmental conditions	Diagnostics of sensor failure	Transmission priority diagnostics (Signal with the highest priority is transmitted)
Temp. T ₁	Level T ₂	Diagnostics T ₃				
23...87 ms	23...87.86 ms	22 ms	Status OK			5
23...87 ms	28,62 ms (13 mm)	66 ms	Level outside the range (<13 mm)	X		4
23...87 ms	87,86 ms (150 mm)	66 ms	Level outside the range (>150 mm)	X		4
≤ 10°C 23...32.6 ms	22 ms (-2.3125 mm)	66 ms	Temperature outside the range for level measurement	X		4
≤ 10°C 23...32.6 ms	22 ms (-2.3125 mm)	66 ms	Level out of range (noise)	X		4
22 ms (-43 to 125°C)	22 ms (-2.3125 mm)	55 ms	Temperature element short-circuited		X	1
23 ms (-40°C)	22 ms (-2.3125 mm)	55 ms	Temperature out of range (low)	X		1
87 ms (-160°C)	22 ms (-2.3125 mm)	55 ms	Temperature out of range (high)	X		1
88 ms (-163 to 125°C)	22 ms (-2.3125 mm)	55 ms	Temperature element broken		X	1
32.6...87 ms	22 ms (-2.3125 mm)	44 ms	Piezoceramics open/short-circuited		X	3
32.6...87 ms	22 ms (-2.3125 mm)	33 ms	Voltage out of range	X		2

$T_3/T = DC$
 $DC = 0.2, 0.3, 0.4, 0.5 \text{ or } 0.6$

T₂: Temperature evaluation (T₂ Level)

$$\text{Temp}_{\text{comp}} [^{\circ}\text{C}] = 3.125 \frac{\text{K}}{\text{ms}} \cdot \left(T_1 \cdot \frac{110 \text{ ms}}{T[\text{ms}]} - 23 \text{ ms} \right) - 40 \text{ K}$$

or

$$\text{Temp}_{\text{comp}} [^{\circ}\text{C}] = \frac{100}{32} \frac{\text{K}}{\text{ms}} \cdot \left(T_1 \cdot \frac{110 \text{ ms}}{T[\text{ms}]} - 23 \text{ ms} \right) - 40 \text{ K}$$

$$\text{diagnostic}[\text{ms}] = T_3[\text{ms}]$$

$$\text{Level}_{\text{comp}} [\text{mm}] = 2.3125 \frac{\text{mm}}{\text{ms}} \cdot \frac{T[\text{ms}]}{110 \text{ ms}} \cdot \left(T_2[\text{ms}] \cdot \frac{110 \text{ ms}}{T[\text{ms}]} - 23 \text{ ms} \right)$$

or

$$\text{Level}_{\text{comp}} [\text{mm}] = 2.3125 \frac{\text{mm}}{\text{ms}} \cdot \left(T_2[\text{ms}] - 23 \text{ ms} \cdot \frac{T[\text{ms}]}{110 \text{ ms}} \right)$$

or

$$\text{Level}_{\text{comp}} [\text{mm}] = \frac{74}{32} \frac{\text{mm}}{\text{ms}} \cdot \left(T_2[\text{ms}] - 23 \text{ ms} \cdot \frac{T[\text{ms}]}{110 \text{ ms}} \right)$$

PWM (open collector) signal evaluation

The PWM output signal consists of three pulses that are repeated cyclically every 1,000 ms ± 10%. The pulses contain encoded information on oil temperature, the oil level and on diagnostics.

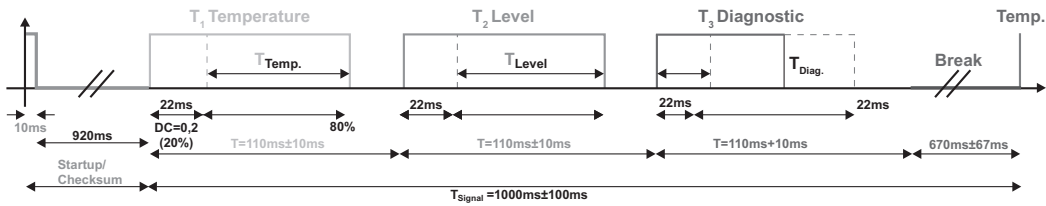

TECHNICAL DETAILS

Technical data

Operating voltage (for oil level measurement)	9 – 16 V
Operating voltage (for temperature measurement)	9 – 16 V
Polarity reversal voltage	-14 V / 60 s
Oversvoltage	15 s at 28 V 250 ms at 32 V
Measuring range (static and dynamic)	13 mm to L -6 mm ¹⁾
Operating temperature	-40°C to +160°C
Operating temperature (for oil level measurement) ¹⁾	-10°C to +150°C
Reheating temperature	max. 5,700 h at 125°C max. 240 h at 145°C max. 60 h at 160°C
Storage temperature	-40°C to +150°C
Current consumption	8 mA
Max. Current consumption during measurement	50 mA
Protocol ²⁾	PWM
Mating connector ³⁾	MLK 872-858-541 (3way 1.2 SealStar)
Protection class	IP 6K9K
Weight	depending on variant
Viscosities	1 mm ² /s to 1,300 mm ² /s

¹⁾ Dependent on damping cup length (see variant overview).

²⁾ Level output above -10°C. At temperatures below -10°C, an "empty" signal is sent (18 mm) together with the diagnostic signal "out of tolerance".

³⁾ This accessory is not included in the scope of delivery. Available from Hirschmann.

Dimensional sketch

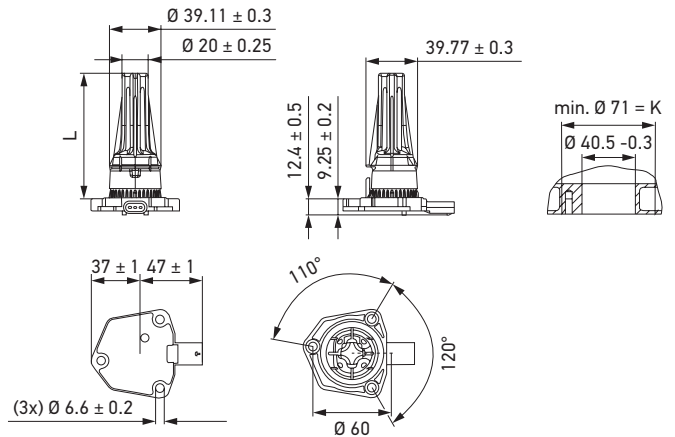

Pin assignment

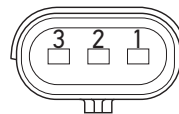

Pin 1: OUTPUT
Pin 2: KL 31 GND
Pin 3: KL 15 V_{BAT}

Tolerance of level measurement

Oil level	Temperature range	Operating voltage	Tolerance
13 mm to L -6 mm	-10°C ≤ T < 30°C	9 to 16 V	±4 mm
13 mm to L -6 mm	30°C ≤ T < 150°C	9 to 16 V	+2 mm

Temperature measurement tolerance

Oil level	Temperature range	Operating voltage	Tolerance
All	60°C ≤ T < 120°C	6 to 16 V	±2 K

HELLA GmbH & Co. KGaA

Rixbecker Straße 75
59552 Lippstadt, Germany
Tel.: +49 2941 38-0
Fax: +49 2941 38-7133
Internet: www.hella.com

© HELLA GmbH & Co. KGaA, Lippstadt
J01695/09.20
Subject to technical and price modifications.

PROGRAMME OVERVIEW



Length of damping cup	Supply voltage	Measuring range	Part number
85 mm	12 V	Static and dynamic 13–79 mm	On request
95 mm	12 V	Static and dynamic 13–89 mm	On request
109,8 mm	12 V	Static and dynamic 13–103,8 mm	On request
135 mm	12 V	Static and dynamic 13–129 mm	On request
150 mm	12 V	Static and dynamic 13–144 mm	On request
Accessories			
Sealing ring*			On request

* Whenever the sensor is remounted, a new sealing ring must be used. This can be obtained from HELLA.