



BRIEF INFORMATION

Horn M28

- Ideal for all kinds of light commercial vehicles and passenger cars.
- Long-life horn with innovative technology
- Compact size and light weight
- Wide-voltage horn available in the range
- Eliminate mechanical wear thanks to electronic design

PRODUCT FEATURES

Application

Signal horns are powered by the battery current pulse, which is normally transmitted via a voltage pulse controlled by the steering wheel. The current signal is sent to a relay, on which the entire control current is transmitted so that no voltage dips occur.

The current signal is sent to a relay, on which the entire control current is transmitted so that no voltage dips occur. As the signal horn is powered by the electric current, a magnetic field is generated which attracts a metal core (shaft) together with a steel membrane. This magnetism causes vibrations that are converted by varying resonances to produce low or high tones.

Design and function

Signal horns are a mandatory part of the safety equipment of a vehicle.

A particularly perceptible sound is necessary in order to be able to warn other road users optimally in dangerous situations. Our signal horns offer you a high level of functional reliability.

TECHNICAL DETAILS

Technical data

Diameter	80 mm
Operating voltage	9 – 15 V
Rated voltage	12 V
Test voltage	13 ± 0.1 V
Current consumption	3.5 A Max
Power consumption	60 W
Operating temperature	-40 °C to +80 °C
Protection class	IP 67
Material Housing	metal black
Frequency range	340 ± 20 Hz (low tone) 415 ± 20 Hz (high tone)
Sound pressure level @ 2 m	105 – 118 dB(A)
Service life	500,000 cycles
Type approval	ECE R28 (service life) ECE R10 (EMC)

Technical drawing

3AL 007 425-427

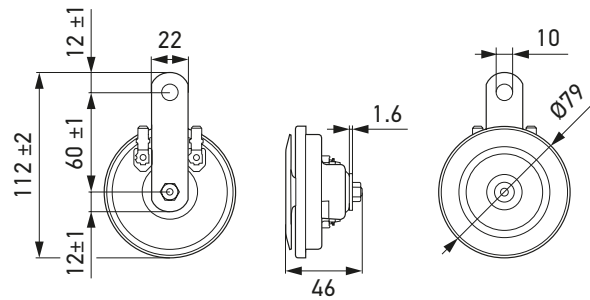

Pin assignment

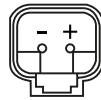

splashwater-proof DEUTSCH plug DT 06-25.

OVERVIEW OF VARIANTS

Product picture	Description	Part number	Packaging unit
	12 V, 335 Hz ± 20 Hz, low tone, flat connector	3AL 007 425-427	32