



BRIEF INFORMATION

Mirror for agricultural and construction vehicles

- Vertical and horizontal mounting on mirror arm possible
- Large adjustment range in x and y positions and also rotatable around the z axis, for optimum visibility
- Surface of chromium-plated glass with highest corrosion resistance
- Reduced weight and optimized ergonomics thanks to slim housing and minimal sized frame
- Modern, aerodynamic style in line with today's vehicle designs

APPLICATION

The mirror is suitable for a wide range of vehicles, such as construction equipment, tele-handlers, front loaders, tractors, sprayers, combine harvesters and other special vehicles.

It is very versatile and offers a convincing solution for the increasing demands of the daily work routine found on construction sites and also on farms.

CUSTOMER BENEFITS

This mirror provides greater safety for the driver during the daily work routine and also in traffic. It has a maximised curvature with a 1,400 mm glass radius, which is fully utilised to increase the driver's indirect field of vision. Because of its compact design, it minimises any obstruction of the driver's direct view in traffic and work situations. In case of an emergency, it can be folded away.

TECHNICAL DETAILS

Technical data

Mounting	Right and left, manually adjustable, large adjustment range in x and y positions and also rotatable around the z axis
Support rod	Ø 18 to 24 mm
Housing	PP housing with high UV stability
Mounting	Pre-assembled screws for easy mounting

Dimensional sketch

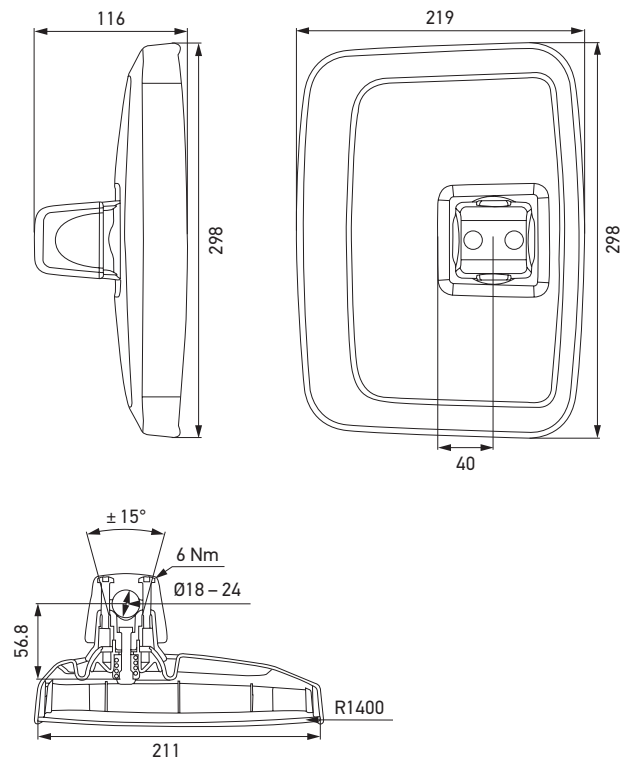

RANGE OVERVIEW

Product image	Description	Part number
	<p>Outside mirror</p> <p>The mirror head can be used on vehicles from the following manufacturers</p> <p>JOHN DEERE / AL221771 CLAAS / 06821462 AGCO INTERNATIONAL GMBH / G737812151020 CATERPILLAR / 558-8103 WACKER NEUSON, KRAMER, EIDEMANN / 1000316535 ATLAS MASCHINEN GMBH / 6163527</p>	8SB 501 550-001



Combination example **8SB 501 550-001** and **8SB 015 039-081**