

## BRIEF INFORMATION

### Pedal sensors

- Contactless measurement
- Slim yet sturdy design
- Simple mechanical connection
- Redundant output signal
- High measurement precision
- No training in the vehicle necessary
- High interference immunity against electrical and magnetic fields

### PRODUCT FEATURES



#### Application

HELLA accelerator pedals designed for upright or pendant mounting can be used in a wide variety of vehicles – ranging from automotive sector applications, such as sports cars and electric vehicles, to robust applications in agricultural and construction vehicles. Thanks to the contactless system of measurement provided by HELLA's own CIPOS® sensor (see description of construction and function) and its extremely low level of mechanical wear, it is advisable to choose such a sensor system over contact-type accelerator pedals, especially for small, frequently recurring movements.

# FLOOR-MOUNTED ACCELERATOR PEDALS

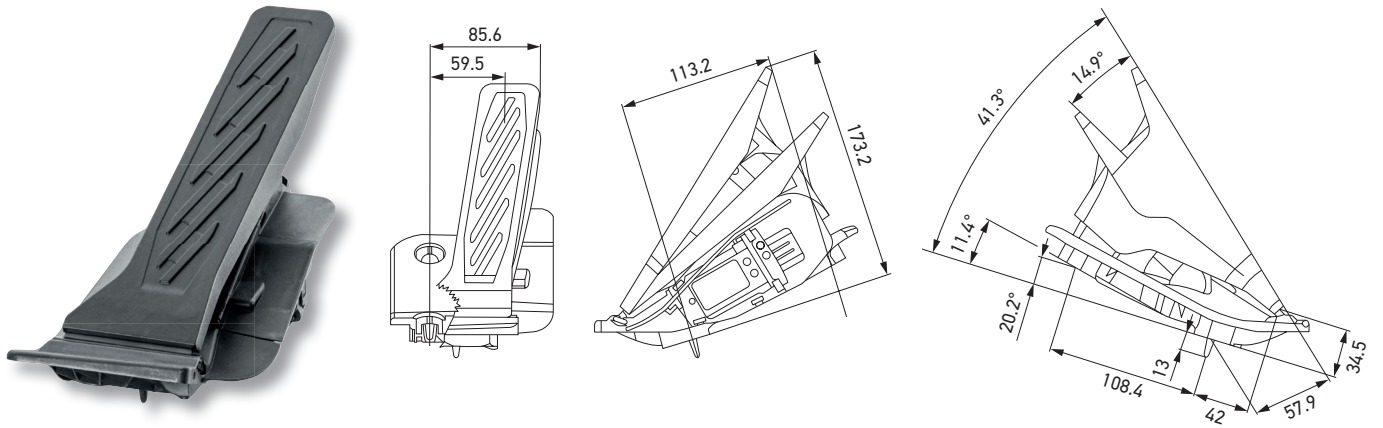

## Design/function

The housing and pedal plate are made entirely from recyclable glass fibre-reinforced plastic. The actuating force is generated by two springs, each individually ensuring safe return to the initial position. The electrical output signal is obtained via the CIPOS® measuring principle. For this purpose, a sheet metal cursor is routed from the pedal plate with a guide rod via sensor conductor paths on the measuring board. Two galvanically isolated sensors then each generate an output signal there.

## Technical data

Operating voltage	5 V ± 6 %
Initial force	15.5 N
Final force	31 N
Actuation angle	15°
Output signal	2 x analogue ratiometric, 2nd channel half pitch
Idling voltage	16 % / 8 %
Full throttle voltage	79 % / 39 %
Operating temperature	-40°C to +85°C
Protection class (electronic)	IP 5K4
Mating connector <sup>1)</sup>	F(6189-1083)

<sup>1)</sup> This accessory is not included in the scope of delivery. Available from Sumitomo. Gold-plated contacts and individual wire sealing are required.

## Mechanical characteristic curve

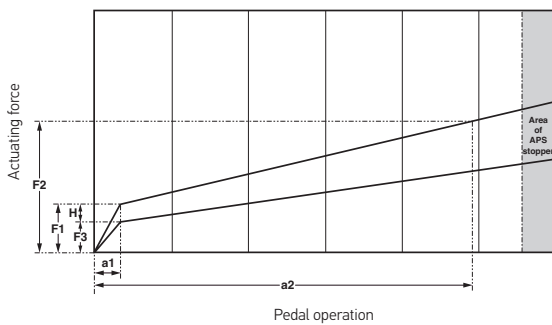

## Electrical characteristic curve

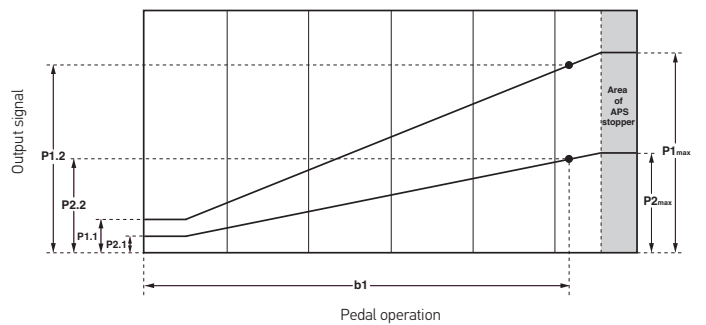

Rated values			
F1	Initial force	Newton (N)	15.5 ± 3.5
F2	Final force	Newton (N)	31 ± 4
F3	Restoring force	Newton (N)	> 5
H	Force hysteresis	Newton (N)	> 6
a1	Starting angle	Degree (°)	< 0.7
a2	End angle	Degree (°)	14.9 ± 0.9

Rated values			
P1.1	Idling voltage S1	Percent (%)	16 ± 0.6
P2.1	Idling voltage S2	Percent (%)	8 ± 0.6
P1.2	Full throttle voltage S1	Percent (%)	78.8 ± 1
P2.2	Full throttle voltage S2	Percent (%)	39.4 ± 1
P1_max	Maximum voltage S1	Percent (%)	91 ± 1
P2_max	Maximum voltage S2	Percent (%)	45.5 ± 1
b1	Full throttle angle	Degree (°)	14

# SUSPENDED PEDALS

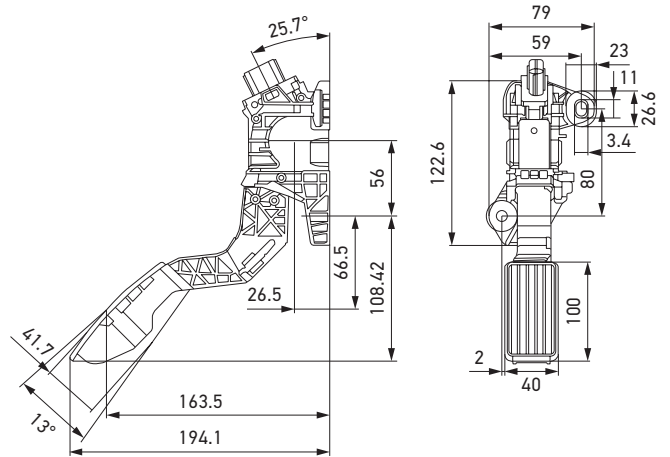
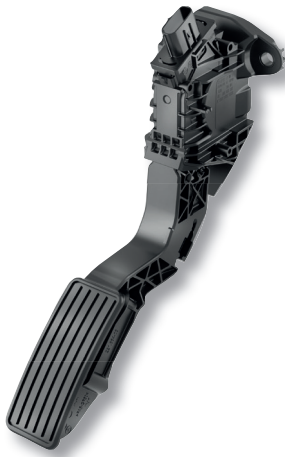

## Design/function

Housing and operating lever are completely made of reusable, glass-fibre reinforced plastic. The actuating force is generated by two springs, each individually ensuring safe return to the initial position. The electrical output signal is obtained via the CIPOS® measuring principle. For this purpose, a sheet metal cursor is routed from the pedal arm via sensor paths on the measuring board. There, two metallically separated sensors each generate an output signal. Different output signals can be generated depending on the measuring board used. In addition, individual characteristic curves can be programmed on request.

## Technical data

Operating voltage	5 V ± 10 %
Initial force	20 N
Final force	35 N
Actuation angle	13°
Output signal	2 x analogue ratiometric, 2nd channel half pitch
Idling voltage	15 % / 7,5 %
Full throttle voltage	88 % / 44 %
Operating temperature	-40°C to +80°C
Protection class (electronic)	IP 5K4
Mating connector <sup>1)</sup>	Sumitomo Denso 6189-1083

<sup>1)</sup>This accessory is not included in the scope of delivery.  
Available from Sumitomo.

## Mechanical characteristic curve

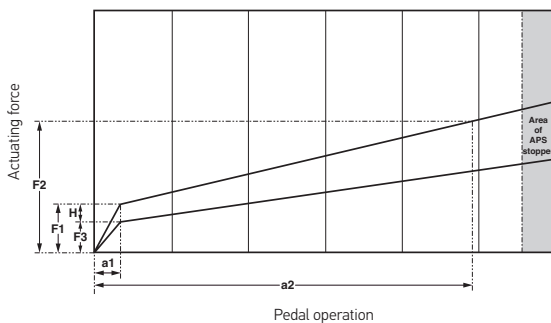

## Electrical characteristic curve

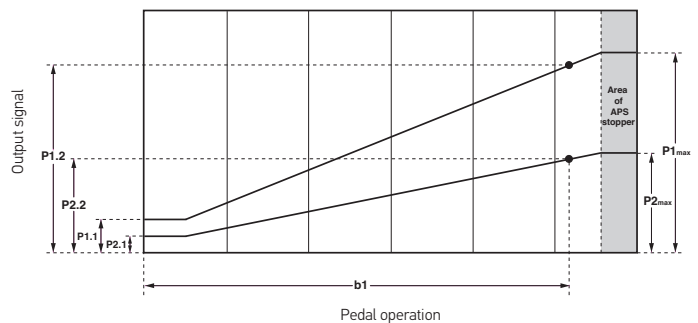

### Rated values

Symbol	Description	Unit	Value
F1	Initial force	Newton (N)	20 ± 4
F2	Final force	Newton (N)	35 ± 5
F3	Restoring force	Newton (N)	> 5
H	Force hysteresis	Newton (N)	> 4
a1	Starting angle	Degree (°)	< 1.1
a2	End angle	Degree (°)	13

### Rated values

Symbol	Description	Unit	Value
P1.1	Idling voltage S1	Percent (%)	15 ± 1
P2.1	Idling voltage S2	Percent (%)	7,5 ± 1
P1.2	Full throttle voltage S1	Percent (%)	88
P2.2	Full throttle voltage S2	Percent (%)	44
P1.max	Maximum voltage S1	Percent (%)	88
P2.max	Maximum voltage S2	Percent (%)	44
b1	Full throttle angle	Degree (°)	11.9 ± 0.6

# PROGRAMME OVERVIEW

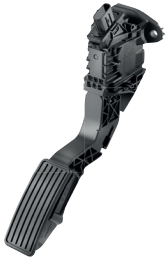
Product image	Variant	Material	Part number
	Accelerator pedal, floor-mounted	Plastic	6PV 312 093-017
	Accelerator pedal, suspended	Plastic	6PV 009 898-007