



BRIEF INFORMATION

SL60 LED

- VISIOTECH projection technology for communication by using light
- Compact warning light for more comfort and safety
- Projection of a red or blue strip-shaped warning line

PRODUCT FEATURES

The innovative SL60 LED warning light from HELLA is fitted with the new VISIOTECH technology. A special lens optic allows the light rays to converge and become so sharply focused that a strip-shaped warning line is projected onto the ground. Depending on the type of mounting, the warning line can be projected in front of the vehicle either horizontally or vertically. This application serves to warn other vehicles or pedestrians of an oncoming vehicle. The lines projected in front of a vehicle can, however, also be used as a means of simpler vehicle navigation. But in both instances, occupational safety and also comfort and convenience are significantly ramped up and consequently accidents are prevented from the outset. Indoors, for example, where forklifts or stackers are in operation, the SL60 LED can even be optimally used during the day, thus greatly facilitating the daily work routine.

Thanks to its compact dimensions, the SL60 LED warning light is particularly well-suited when little space is available for installation. And in addition to its compact size, this lighting system also scores points thanks to its high levels of energy efficiency. Its power consumption of a maximum of 7 watts makes this warning light ideal for use on battery-powered vehicles or on vehicles where the alternator is already under a heavy load. An operating voltage of 10 up to 80 volts is made possible by the multi-voltage electronics present. This then, for example, enables use on 48 V forklifts and similar vehicles with a high vehicle electric system voltage. Models of the SL60 LED warning light are available either with a red projection line or with a blue one, options which make it suitable for the most diverse kinds of applications and target groups.

TECHNICAL DETAILS

Technical Data

Operating Voltage/ Rated Voltage	10–80 V
Light Source Type	LED
Power Consumption	Red: 5.5 W Blue: 7 W
Protection Class	IP 6K7 / IP 6K9K
Type Approval	ECE-R10
Housing	Aluminum Die Cast
Protection	Polarity Reversal Protection
Mounting	Horizontal or Vertical (direction of strip) as required
Connection	500 mm cable
Lens Material	Polycarbonate
Dimensions	70 x 63 x 99 mm
Projected Symbol	Strips (red or blue)
Weight	290 g

Dimensional Sketch

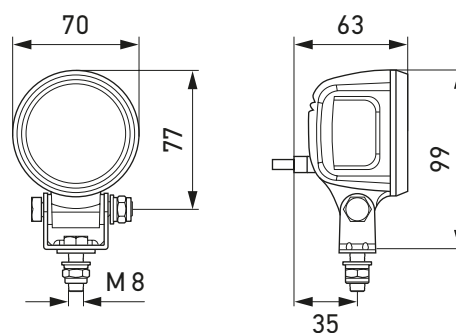

APPLICATION EXAMPLES



RANGE OVERVIEW

1G0 996 210-...	-001	-011
Light strip, blue	X	-
Light strip, red	-	X