



BRIEF INFORMATION

Projection Module

- VISIOTECH projection technology for communication using light
- Projection of warning symbols and also marking of danger zones
- Providing more comfort and safety during the daily work routine

PRODUCT FEATURES

Vehicle lighting plays an important role when it is a question of safety and a convenient working environment. There are many situations where there is still room for improvement especially when it comes to occupational safety. Therefore it is important that hazard zones can be optically marked or demarcated at any time so that everyone in the affected area can be warned and protected in good time. Previously this had to be done by the driver or by other workers, who would manually mark off the areas concerned. This meant that it was not possible to demarcate individual areas as required in a simple, swift and safe action.

But with its VISIOTECH projection technology, HELLA has developed a Projection Module which can project a symbol for a danger zone, traffic sign 101, as a warning onto the ground and thus optically warn other drivers or passers-by. It draws attention to any danger or it can optically delineate certain work areas.

If so required, other projections can be developed and set up in collaboration with customers. Especially in the construction and mining industry, it is important that when, for example, shovels or dump trucks are being unloaded, the danger zone is marked clearly and easily for everyone on site to see.

As a result of frequently "jumping down" from their vehicles, employees working for municipal services are regularly exposed to serious danger that could be caused by other road users. Just one simple warning sign projected onto the working area before any worker "jumps down" could effectively warn car drivers and consequently prevent accidents from happening.

For trucks, transport for disabled persons or emergency vehicles, the required loading or safety areas, for example, can be marked clearly and unambiguously.

Similarly, in the case of forestry and agricultural machinery, there are countless applications which can be implemented in order to achieve more safety and convenience during the daily work routine.

This significantly improves operational safety and convenience during routine operations at any time of the day or night.

The Projection Module may be commissioned for applications that fall outside the German vehicle licensing regulations (StVO). Special approvals are required for special-purpose applications in road traffic.

TECHNICAL DETAILS



Technical data

Operating voltage	Multi-voltage (9 – 60 V)
Rated voltage	12 V / 24 V / 48 V
Power consumption	27 W
Light output	LED circuit board: 2,000 lm
Light source	LED
Material	Housing: die-cast aluminium
Weight	1,150 g
Protection class	IP 6K9K, IP 6K8
EMC protection	ECE-R10
Mounting	Upright and pendant possible, bracket and fixing material not included in the scope of delivery*
Connection	Integrated Tyco Micro Timer including 2,000 mm cable
Recommended angle of inclination	30°
Manufactured in	Austria

* Brackets can be provided on request following evaluation of the mounting circumstances.

Dimensional sketch

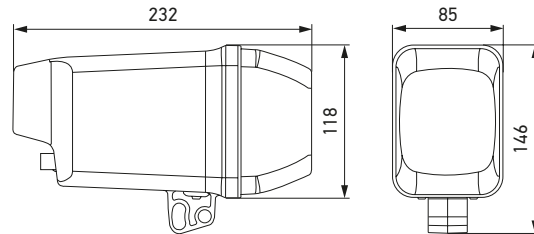

Projection

Possible applications



Waste collection



Loading zone



Bus

PROGRAMME OVERVIEW

Projected symbol

Danger zone traffic sign 101

Part number

2XA 996 200-101

MOUNTING RECOMMENDATION

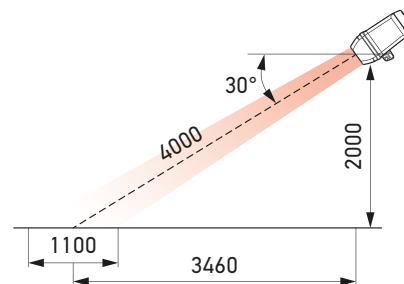
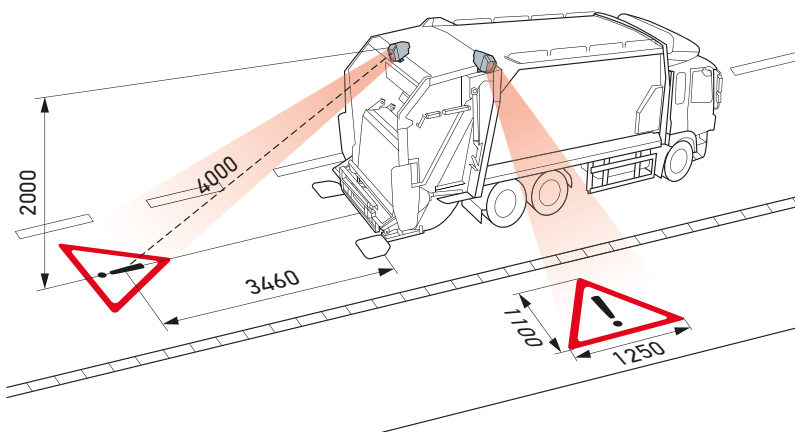

The Projection Module may be commissioned for applications that fall outside the German vehicle licensing regulations (StVO). Special approvals are required for special-purpose applications in road traffic.