



BRIEF INFORMATION

Locking actuator

- › Electrical locking/ unlocking, space-saving, with or without micro switch
- › Compact, space-saving design
- › Electromotive reset or automatic (non-electric) reset
- › Easy to mount thanks to snap-fit mounting
- › Splash-proof
- › With or without micro switch
- › Explosion report for tank modules

PRODUCT FEATURES

Application

The extremely space-saving design of this actuator makes it especially suitable for locking and unlocking applications in dry and wet areas (also via remote control, for example) where there is only limited space available.

Examples include:

- Tank modules
- Service flaps
- Glove compartments
- Locking of charging plugs (e-mobility)

PRODUCT FEATURES

Design and function

When a voltage is applied, the motor integrated in the electromotive actuator moves the locking lever attached to the motor shaft.

There are two product variants available in the product range. The first variant of the actuator with electrical locking and unlocking function is particularly suitable for traditional applications, where the locking lever locks a hinged arm attached to the locking system by applying a voltage and then unlocks it by reversing the voltage polarity. The stability of the open/closed locking positions is achieved by the motor being short-circuited following successful triggering. The position of the locking element can also be defined via an integrated micro switch.

The second actuator variant has a return spring and a micro switch integrated. The micro switch is actuated by a slight movement of the locking lever, e.g. by pressing a service flap. Current is then applied to the actuator via a control unit. This makes the actuator locking lever retract completely, leaving the closing system open and triggering the spring-loaded opening of the service flap. The actuator is then switched off and the integrated return spring causes the locking lever to return to the locking position without the use of any current. In order to lock the service flap, this flap is pushed closed when the hinged arm of the service flap snaps into the actuator's locking lever.

Mounting interface example

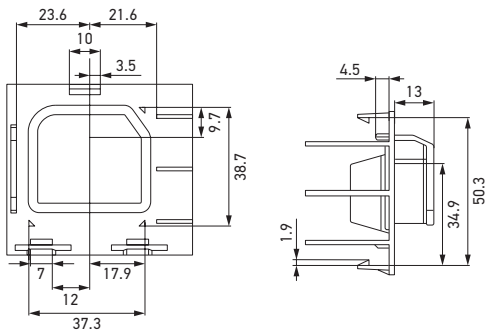

Locking interface (Variant -087 und -097)

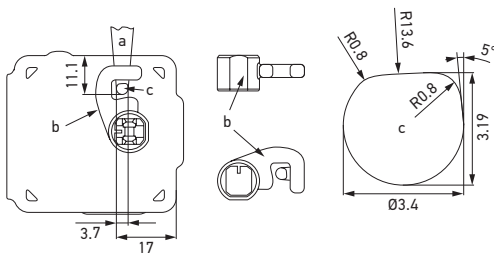

a = Closing bar
 b = Locking element
 c = Closing bar pin

Locking interface (Variant -047)

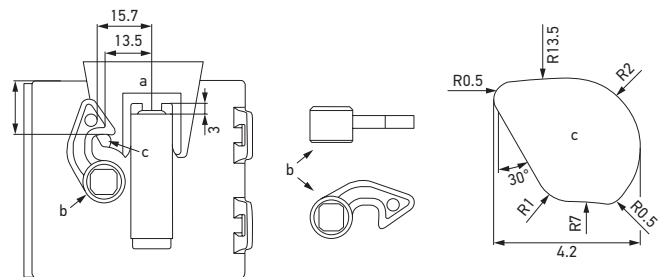

a = Closing bar
 b = Locking element
 c = Closing bar pin

TECHNICAL DETAILS

6NW 011 122-087

Technical data

Operating voltage range	Single-voltage (9 – 15.5 V)
Rated voltage	12 V
Function	Electrical forward and reverse rotation
Weight	60 g
Maximum current consumption (stall current)	≤ 3.2 A
No-load current	≤ 2.0 A
Locking lever pulling force	> 75 N (after lifetime > 50 N)
Locking lever breaking force	≥ 300 N
Functional angle	≤ 78°
Actuating time for 78° via functional angle ¹⁾	40 ms < t < 200 ms
Triggering time	0.2 s < t < 10 s
Minimum switch on-time	t _{on, min} = 200 ms
Maximum switch on-time	t _{on, max} = 10 s
Breaking time	8 × t _{on}
Thermal overload protection	Not available
Temperature range	-40 °C to +85 °C
Storage temperature	-40 °C to +90 °C
Lifetime ²⁾	100,000 cycles
Compliant	Conducted electromagnetic interference: DIN ISO 7637, SAE J1113-42 Interference suppression CISPR 25, SAE J-1113-41: Intensity level 1 + 10 dB µV
End position stability with motor short circuit	≤ 6°
Protection class	IP 5K4
Salt spray test in accordance with DIN 50 021 SS	96 h
Vibration resistance in accordance with IEC 68-2-64	2.7 g
Material	Housing: PP-GF30 Locking lever: PAA GF60
Sealing ring	NBR 70 Shore A
Resistant to	Petrol, diesel, biodiesel, ozone
Pin coating	Galvanically tin-plated
Connector	Hirschmann, 3-pin
Mating connector ³⁾	3-pin MLK coupling ELA 872-858-541

¹⁾ Over the operating voltage and temperature range.

²⁾ One switching cycle equals one open and return rotation. 0.7 s on, 14 s off (reverse voltage)

³⁾ These accessories are not included in the scope of delivery. Available from Hirschmann Automotive.

Dimensional sketch

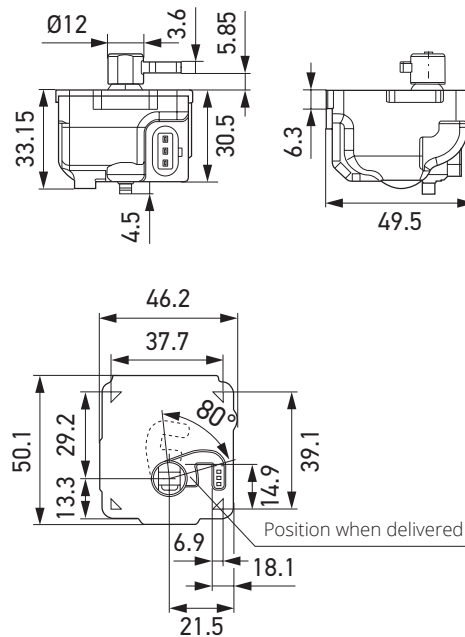

Pin assignment / electrical connection

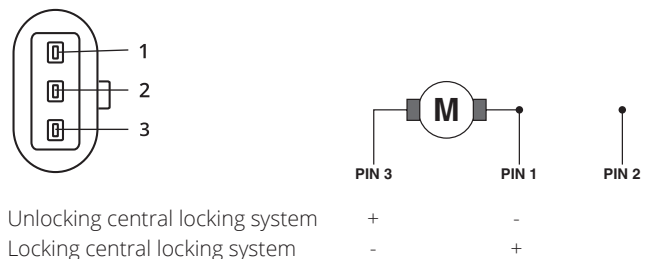

TECHNICAL DETAILS

6NW 011 122- 097, -107 UND -117

Technical data	
Operating voltage range	Single-voltage (9 – 15.5 V)
Rated voltage	12 V
Function	Electrical forward and reverse rotation, with micro switch (-097)
	Electrical forward and reverse rotation with micro switch, without operating element, without locking element (-107),
	Electrical forward and reverse rotation with micro switch, with operating element, without locking element (-117)
Weight	60 g
Maximum current consumption (stall current)	≤ 2.4 A
No-load current	≤ 1.0 A
Locking lever pulling force	≥ 75 N
Locking lever breaking force	≥ 300 N
Functional angle	≤ 78°
Actuating time for 78° via functional angle ¹⁾	40 ms < t < 200 ms
Triggering time	0.2 s < t < 10 s
Minimum switch on-time	t _{on, min} = 200 ms
Maximum switch on-time	t _{on, max} = 10 s
Breaking time	8 x t _{on}
Thermal overload protection	Not available
Temperature range	-40 °C to +85 °C
Storage temperature	-40 °C to +90 °C
Lifetime ²⁾	60,000 cycles
Compliant	Conducted electromagnetic interference: Intensity level 2
	Interference suppression CISPR 25, SAE J-1113-41: ≤ 18 mm, Intensity level 1 + 10 dB µV
Micro switch switching angle	8° to 18°
End position stability with motor short circuit	≤ 6°
Protection class	IP 5K4
Salt spray test in accordance with DIN 50 021 SS	96 h
Vibration resistance in accordance with IEC 68-2-64	2.7 g
Material	Housing: PP-GF30 Locking lever: PAA GF60
Sealing ring	NBR 70 Shore A black
Resistant to	Petrol, diesel, biodiesel, ozone
Pin coating	Galvanically tin-plated
Connector	Hirschmann, 3-pin
Mating connector ³⁾	3-pin MLK coupling ELA 872-858-...KA

¹⁾ Over the operating voltage and temperature range.

²⁾ One switching cycle equals one open and return rotation. 0,7 s on, 14 s off (reverse voltage)

³⁾ These accessories are not included in the scope of delivery. Available from Hirschmann Automotive.

Dimensional sketch

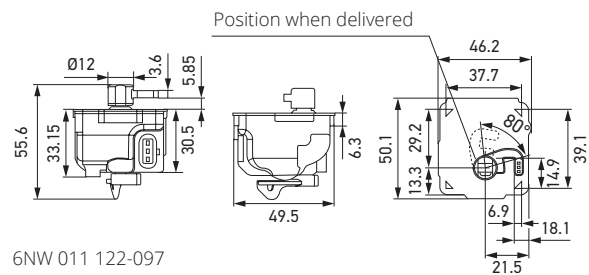

6NW 011 122-097

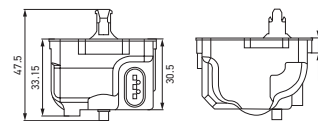

6NW 011 122-107

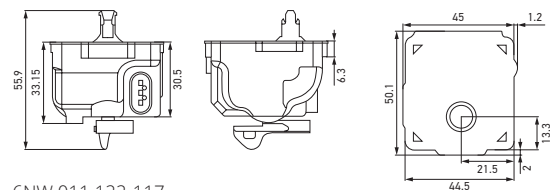

6NW 011 122-117

Pin assignment / electrical connection

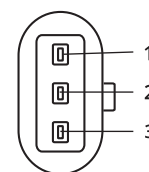

Unlocking
Locking

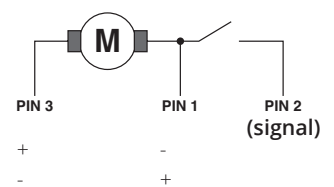

PIN 3

+

-

PIN 1

-

+

PIN 2

(signal)

MICRO SWITCH TRIPPING

6NW 011 122- 097, -107 UND -117

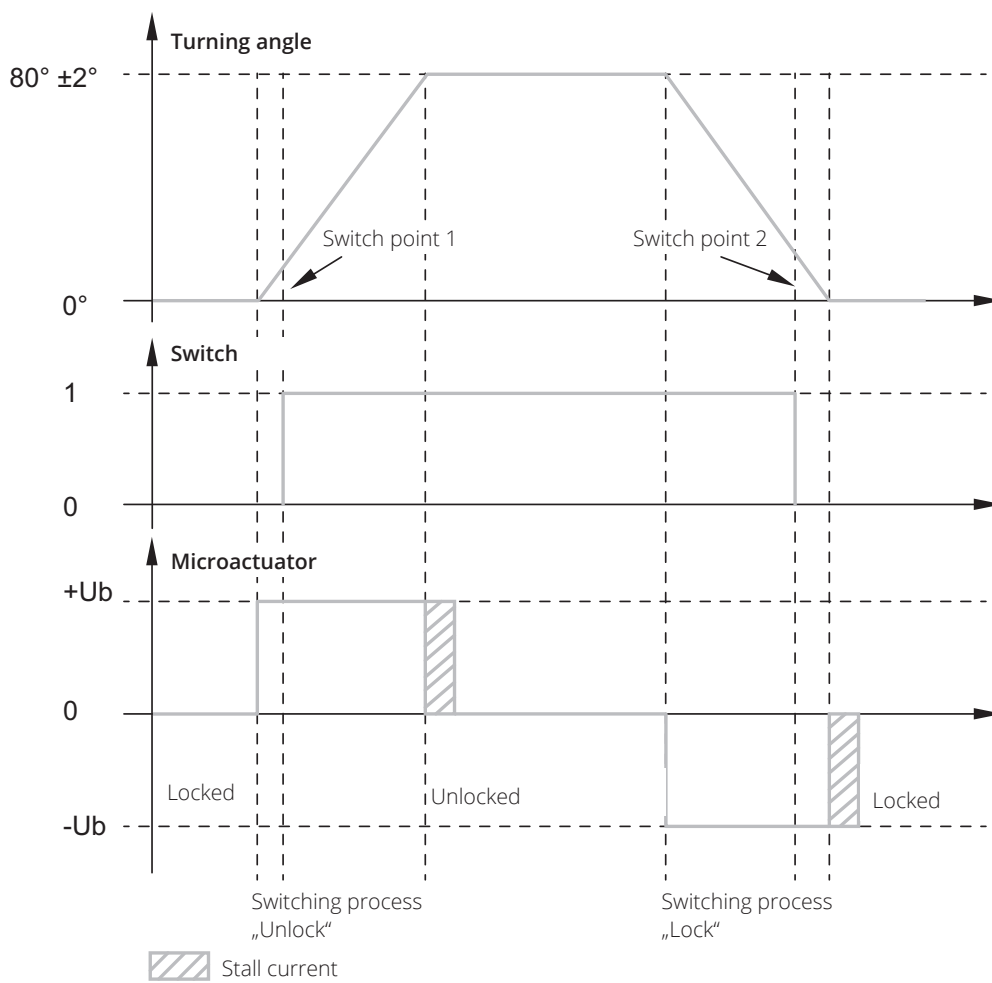

TECHNICAL DETAILS

6NW 011 122-047

Technical data

Operating voltage range	Single-voltage (9 – 15.5 V)
Rated voltage	12 V
Function	Electrical forward rotation, return rotation via return spring, with soft-touch button
Weight	60 g
Maximum current consumption (stall current)	≤ 4.0 A
No-load current	≤ 2.0 A
Locking lever pulling force	75 N
Locking lever breaking force	300 N
Micro switch triggering force	≤ 24 N
Functional angle	≤ 78°
Actuating time for 78° via functional angle ¹⁾	45 ms < t < 220 ms
Triggering time	0.3 s < t < 4 s
Minimum switch on-time	t _{on, min} = 300 ms
Maximum switch on-time	t _{on, max} = 4 s
Breaking time	20 x t _{on}
Thermal overload protection	Not available
Temperature range	-40 °C to +85 °C
Storage temperature	-40 °C to +90 °C
Lifetime ²⁾	10,000 cycles
Compliant	Conducted electromagnetic interference: DIN ISO 7637, SAE J1113-42
	Interference suppression CISPR 25, SAE J-1113-41: Intensity level 1 + 10 dB µV
Micro switch switching angle	8° to 18°
End position stability with motor short circuit	≤ 6°
Protection class	IP 5K4
Salt spray test in accordance with DIN 50 021 SS	96 h
Vibration resistance in accordance with IEC 68-2-64	2.7 g
Material	Housing: PP-GF30 Locking lever: PAA GF60
Sealing ring	NBR 70 Shore A
Resistant to	Petrol, diesel, biodiesel, ozone
Pin coating	CuSn6, bronze plate, galvanically tin-plated
Connector	Hirschmann, 3-pin
Mating connector ³⁾	3-pin MLK coupling ELA 872-858-541

¹⁾ Over the operating voltage and temperature range.

²⁾ One switching cycle equals one open and return rotation. 0.7 s on, 14 s off (reverse voltage)

³⁾ These accessories are not included in the scope of delivery. Available from Hirschmann Automotive.

Dimensional sketch

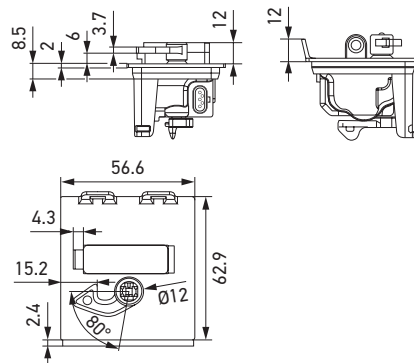

Pin assignment / electrical connection

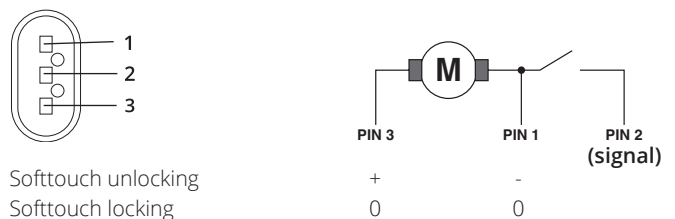

Softtouch unlocking
Softtouch locking

SWITCHING PROCESS FUNCTION SEQUENCE

6NW 011 122-047

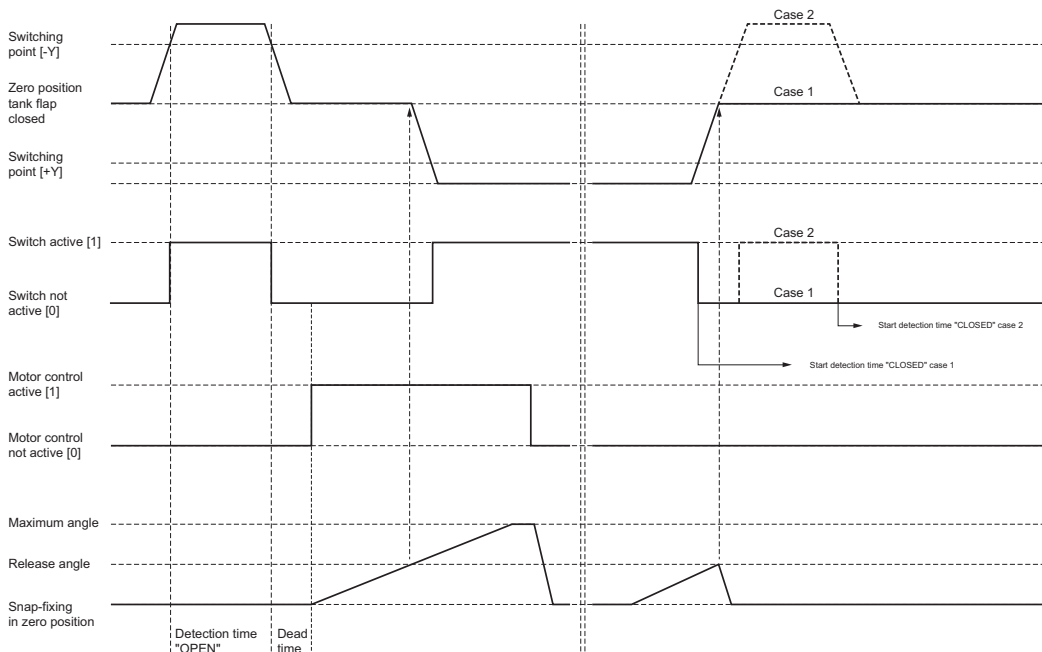

Detection time „OPEN“

Description:
Minimum period of time that the operator has to hold the operating element depressed for opening to take place.

Explanation:
In order that short pulses do not lead to unintentional opening, the „Open“ detection time starts when the status changes from [0], operating element not depressed, to [1], operating element depressed. If the state [1] „Switch active“ is detected for longer than the preset value, opening is initiated when the state changes from [1] to [0].

Dead time

Description:
Time between switch change to [0] and activation of the motor control [1] when an opening process is initiated.

Explanation:
On the electronic side, there occurs a system reaction time comprising switch debouncing and the system runtime. This can result in a delay of up to 70 ms, which then extends the non-parameterisable (actual) dead time of the opening process.

Detection time „CLOSED“

Description:
Minimum time that the application has to be closed before a new opening process can be initiated by the operator.





Explanation:
When the application is open, the switch signal is active [1]. As soon as the operator closes the application, the switch signal changes to inactive [0]. The „CLOSED“ detection time starts to run when the switch is set to inactive [0]. Two instances are possible when closing (see case studies).

Case studies

Case 1:
The operator does not press down to the end stop when closing the application. The signal changes from „Switch active“ [1] to „Switch not active“ [0] and the detection time „CLOSED“ starts. As soon as the preset time has expired, the application can be reopened.

Case 2:
When closing the application, the operator presses down to the end stop. This means that the signal first changes from „Switch active“ [1] to „Switch not active“ [0] and the „CLOSED“ detection time starts. When the operator presses down again to the end stop, the signal changes back to „Switch active“ [1] and the detection time „CLOSED“ which has not yet expired is reset. As soon as the operator releases the application, the signal changes to „Switch not active“ [0] and the „CLOSED“ detection time starts again.

PROGRAM OVERVIEW

Product picture	Function	Manual adjustment	Part number	VPE*
	Electrical forward and reverse rotation	No	6NW 011 122-087	175
	Electrical forward and reverse rotation, with micro switch	No	6NW 011 122-097	175
	Electrical forward and reverse rotation with micro switch, without operating element, without locking element	No	6NW 011 122-107	175
	Electrical forward and reverse rotation with micro switch, with operating element, without locking element	No	6NW 011 122-117	175
	Electrical forward rotation, return rotation via return spring, with soft-touch button	Yes	6NW 011 122-047	60

* Packaging unit